

**United States Court of Appeals
for the Federal Circuit**

FREE STREAM MEDIA CORP., DBA SAMBA TV,
Plaintiff-Appellant

v.

**ALPHONSO INC., ASHISH CHORDIA, LAMPROS
KALAMPOUKAS, RAGHU KODIGE,**
Defendants-Cross-Appellants

2019-1506, 2019-2133

Appeals from the United States District Court for the
Northern District of California in No. 3:17-cv-02107-RS,
Judge Richard Seeborg.

Decided: May 11, 2021

MATTHEW D. POWERS, Tensegrity Law Group LLP,
Redwood Shores, CA, argued for plaintiff-appellant. Also
represented by WILLIAM P. NELSON, DANIEL RADKE,
JENNIFER ROBINSON, NATASHA SAPUTO.

INDRA NEEL CHATTERJEE, Goodwin Procter LLP, Red-
wood City, CA, argued for defendants-cross-appellants.
Also represented by ELIZABETH J. LOW, ANDREW S. ONG;
DAVID ZIMMER, Boston, MA.

Before DYK, REYNA, and HUGHES, *Circuit Judges*.

REYNA, *Circuit Judge*.

Free Stream Media Corp. d/b/a Samba TV appeals a summary judgment of noninfringement from the Northern District of California and a claim construction order from the Eastern District of Texas. Alphonso Inc. cross-appeals a denial of its motion to dismiss under 35 U.S.C. § 101 from the Northern District of California. We reverse the Northern District of California's judgment denying Alphonso's motion to dismiss and do not reach the grant of summary judgment of noninfringement in favor of Alphonso. In addition, we affirm the Eastern District of Texas's claim construction order.

BACKGROUND

Procedural History

In November 2015, Free Stream Media Corp. d/b/a Samba TV ("Samba") asserted infringement of U.S. Patent No. 9,026,668 ("the '668 patent") in the Northern District of California. Later, in a separate case, Samba asserted U.S. Patent No. 9,386,356 ("the '356 patent") against Alphonso Inc. ("Alphonso") in the Eastern District of Texas. Both cases were consolidated by stipulation of the parties and later transferred to the Northern District of California. In March 2017, just before transfer, the Texas district court construed a disputed term of the asserted claims for both patents.

Upon transfer to the California district court, and based on the Texas district court's claim construction, Samba stipulated to noninfringement as to the '668 patent. Thereafter, Alphonso filed a motion to dismiss on grounds that the asserted claims of the '356 patent are patent ineligible subject matter under § 101. The district court denied the motion to dismiss. J.A. 1418–23; ECF No. 277. In its decision, the district court treated claim 1 of the '356 patent as representative, J.A. 1418, and concluded that the claim

was not directed to an abstract idea of tailored advertising as argued by Alphonso, J.A. 1421, 1423. The district court found that the '356 patent “describes systems and methods for addressing barriers to certain types of information exchange between various technological devices, *e.g.*, a television and a smartphone or tablet being used in the same place at the same time.” J.A. 1421.

In April 2018, Alphonso moved for reconsideration of its motion to dismiss or, alternatively, to certify interlocutory appeal and stay, and that too was denied. In December 2018, the California district court granted Alphonso summary judgment of noninfringement as to the asserted claims of the '356 patent.

Samba appeals the grant of summary judgment of noninfringement and the Texas district court's claim construction order. Alphonso cross-appeals the California district court's denial of its motion to dismiss. We have jurisdiction under 28 U.S.C. § 1295(a)(1).

The '356 Patent

The '356 patent is entitled “Targeting with Television Audience Data Across Multiple Screens.” The patent generally relates to a system providing a mobile phone user with targeted information (*i.e.*, advertisements) that is deemed relevant to the user based on data gathered from the user's television. *See generally* '356 patent. The asserted claims utilize three main components: (1) a networked device (*e.g.*, a smart TV); (2) a client device (*e.g.*, a mobile device); and (3) a relevancy matching server. *See* '356 patent Fig. 2; J.A. 303; Appellant's Br. at 4. The district court treated claim 1 as representative for purposes of Alphonso's motion to dismiss. J.A. 1418.¹ The district court acknowledged that Samba was continuing to allege

¹ Samba asserts claims 1, 10, 13, 18, and 20 of the '356 patent; claims 13, 18 and 20 depend from claim 10.

infringement of claim 10 but stated that Samba conceded claims 1 and 10 are similar. Because claim 10 was treated as representative in the summary judgment decision, we discuss both claims 1 and 10 for purposes of this court's eligibility analysis.²

1. A system comprising:

a television to generate a fingerprint data;

a relevancy-matching server to:

match primary data generated from the fingerprint data with targeted data, based on a relevancy factor, and

search a storage for the targeted data;

wherein the primary data is any one of a content identification data and a content identification history;

a mobile device capable of being associated with the television to:

process an embedded object,

constrain an executable environment in a security sandbox, and execute a sandboxed application in the executable environment; and

a content identification server to:

process the fingerprint data from the television, and

² Claim 10 was treated as the representative claim in the California district court's summary judgment decision. Because we conclude that both claims are directed to an abstract idea, we need not reach the merits of Samba's appeal of the summary judgment decision.

communicate the primary data from the fingerprint data to any of a number of devices with an access to an identification data of at least one of the television and an automatic content identification service of the television.

'356 patent at col. 51 l. 62–col. 52 l. 16.

10. A relevancy-matching server communicatively coupled with a television and a mobile device through a network, comprising:

a processor;

a memory communicatively coupled with the processor; and

instructions stored in the memory and executed using the processor configured to:

match primary data generated using a fingerprint data with targeted data, based on a relevancy factor comprising at least one of a category of the primary data, a behavioral history of a user, a category of a sandboxed application, and another information associated with the user,

search a storage for the targeted data,

wherein the primary data is any one of a content identification data and a content identification history, and

wherein the relevancy-matching server is to cause a rendering of the targeted data to the user through the sandboxed application of the mobile device.

Id. at col. 53 ll. 8–27.

The network device collects primary data, which can consist of program information, location, weather information, or identification information. *See, e.g., id.* at col. 4 ll. 39–45. There are two ways the primary data is collected: either directly, such as by identifying the show title of a specific commercial being broadcasted, or by using preliminary data, which includes watermarks. *See, e.g., id.* at col. 11 ll. 3-12; col. 20 ll. 48–52. Watermarks are audio or video “snippets” called fingerprints that can be converted into primary data. *See* Order Denying Motion to Dismiss, ECF No. 277 at 2.

The client device may be a smartphone, computer, or other hardware on which applications run and advertisements may be shown. *See* ’356 patent at col. 6 ll. 60–63. The client device includes a security sandbox, which is a security mechanism for separating running programs. *See generally id.* at col. 11 ll. 20–26. According to the specification,

[t]he security sandbox may constrain what each of the number of applications is allowed to do. For example, the security sandbox may limit access to the network, thereby making it difficult for the client device to find the networked device of the user and/or to obtain information directly from the networked device. Such information may include what is currently playing on the networked device.

Id. at col. 11 ll. 5–12 (patent reference numbers omitted).

Finally, a relevancy-matching server uses primary data from the networked device to select advertisements or other targeted data based on a relevancy factor associated with the user. Further, the relevancy-matching server “may also be configured to render the targeted data to the user through the networked device and/or the sandboxed application of the client device.” *Id.* at col. 12 ll. 59–64 (patent reference numbers omitted); *see also id.* at col. 3 ll. 16–21.

A detailed review of the specification demonstrates that security sandboxes may be in place either at the operating system level, so that a user application “could not corrupt the traditional operating system,” or at the application level, “so that each of the number of applications cannot access [] data of an other application.” *Id.* at col. 11 ll. 15–26. The specification explains that the security sandbox may be “bypass[ed]” by establishing “a communication session between the sandboxed application and the sandbox-reachable service” of the networked device. *See id.* at col. 3 ll. 37–45. Specifically, “[t]he communication session may be established between the sandboxed application [within a client device] and the sandbox-reachable service [within a networked device] through [a] cross-site scripting technique, [an] appended header, [a] same origin policy exception, and/or [an] other mode of bypassing a number of (e.g., at least one) access controls of the security sandbox.” *Id.* at col. 7 ll. 3–9 (patent reference numbers omitted). The communication session may exist directly between the client device and the networked device, or indirectly (e.g., through a pairing server). *Id.* at col. 11 l. 63–col. 12 l. 4 (patent reference numbers omitted).

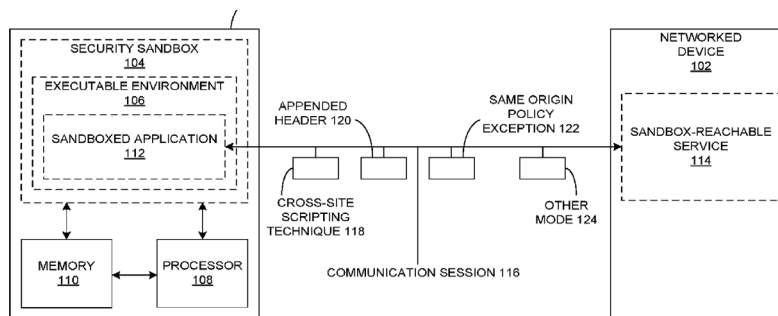

Id. at Fig. 1. The specification discloses various mechanisms that can be used to bypass the security sandbox. First, the specification describes the “cross-site scripting technique” as using a “computer security vulnerability that enables an injection of a client-side script to bypass the

number of access controls.” *Id.* at col. 12 ll. 6–10. Second, the patent discloses the “appended header,” which is described as “a mechanism . . . that allows a cross-domain request by adding a new header.” *Id.* at col. 12 ll. 12–16. Next, the patent discusses the “same origin policy exception,” which may be “a technique for relaxing a rule preventing an access to . . . a number of different sites.” *Id.* at col. 12 ll. 19–25. Finally, the disclosure explains that the “other mode” may be “a mechanism of bypassing a number of access controls of the security sandbox” by enabling multicast, broadcast, or an anycast-based discovery protocol or by enabling a “pairing via an entry of a short code and/or an account name in the client device [] and/or the networked device.” *Id.* at col. 12 ll. 26–37. All of this can be done without intervention from the user of the client device. *See id.* at col. 2 ll. 46–59. Notably, the specification does not provide for any other mechanism that can be used to bypass the security sandbox other than “through a cross-site scripting technique, an appended header, a same origin policy exception, and/or an other mode of bypassing a number of access controls of the security sandbox.” *Id.* at col. 3 ll. 37–45. The specification states that all of these mechanisms exist “as a component of the communication session.” *Id.* at col. 12 ll. 5–30.

DISCUSSION

I

U.S. patent law provides that a patent may be obtained for: processes, machines, manufactures, and compositions. *See* 35 U.S.C. § 101. But there are exceptions. “Laws of nature, natural phenomena, and abstract ideas are not patentable.” *Alice Corp. Pty. Ltd. v. CLS Bank Int’l*, 573 U.S. 208, 216 (2014).

Patent eligibility under § 101 is a question of law that may involve underlying questions of fact. *Berkheimer v. HP Inc.*, 881 F.3d 1360, 1365 (Fed. Cir. 2018). To determine whether an invention claims ineligible subject

matter, we engage in a two-step process established by the Supreme Court in *Alice*.

At Step 1, “we determine whether the claims at issue are directed to one of [the] patent-ineligible concepts,” i.e., laws of nature, natural phenomena, or abstract ideas. *Alice*, 573 U.S. at 217. The inquiry may entail looking to the “focus of the claimed advance” over the prior art to see if the character of the claim as a whole, considered in light of the specification, is directed to ineligible subject matter. *Trading Techs. Int’l, Inc. v. IBG LLC*, 921 F.3d 1378, 1384 (Fed. Cir. 2019).

If we determine that the patent is drawn to an abstract idea or otherwise ineligible subject matter, we consider at Step 2 “the elements of each claim both individually and ‘as an ordered combination’ to determine whether the additional elements ‘transform the nature of the claim’ into a patent-eligible application.” *Alice*, 573 U.S. at 217 (quoting *Mayo Collaborative Servs. v. Prometheus Labs., Inc.*, 566 U.S. 66, 78–79 (2012)). We analyze whether there is an “inventive concept” that takes the claim into the realm of patent eligibility. *Id.* at 217–19; *see also Elec. Power Grp., LLC v. Alstrom S.A.*, 830 F.3d 1350, 1353 (Fed. Cir. 2016); *Enfish, LLC v. Microsoft Corp.*, 822 F.3d 1327, 1335 (Fed. Cir. 2016).

We review a district court’s dismissal for failure to state a claim under the law of the regional circuit—here, the Ninth Circuit. *See BASCOM Glob. Internet Servs., Inc. v. AT&T Mobility LLC*, 827 F.3d 1341, 1347 (Fed. Cir. 2016). The Ninth Circuit reviews the grant of a motion to dismiss de novo. *See Skilstaf, Inc. v. CVS Caremark Corp.*, 669 F.3d 1005, 1014 (9th Cir. 2012).

A. Step 1

The district court concluded that claim 1 was not directed to an abstract idea of tailored advertising as argued by Alphonso. J.A. 1421. Rather, the district court

determined that the '356 patent “describes systems and methods for addressing barriers to certain types of information exchange between various technological devices, e.g., a television and a smartphone or tablet being used in the same place at the same time.” *Id.*

In its cross-appeal, Alphonso contends that the district court erred in concluding that the '356 patent is not directed to patent-ineligible subject matter because the '356 patent is directed to the abstract idea of targeted advertising. We agree. Our review of both claims 1 and 10 of the '356 patent reveals that the claims are directed to: (1) gathering information about television users' viewing habits; (2) matching the information with other content (i.e., targeted advertisements) based on relevancy to the television viewer; and (3) sending that content to a second device.

Samba argues that claims 1 and 10 are directed to a specific asserted improvement in computer capabilities, namely “television and mobile devices that operate with respect to each other differently from conventional televisions and mobile devices.” Appellant's Resp. & Reply Br. at 41 (internal quotation marks and citations omitted); *see also* Appellee's Reply Br. at 1 (acknowledging that Samba asserts its claims address purported technological barriers that prevent “Internet-connected devices, such as a television and a mobile device, from communicating with one another”). In support of its assertion, Samba contends that its claimed invention is like those previously found eligible in *Enfish*, *Visual Memory*, *Finjan*, *Core Wireless*, and *Uniloc*. *Id.* at 40; *see cases cited infra* note 3. More specifically, Samba argues that claim 1 is “specifically directed to a system wherein a television and a mobile device are intermediated by a content identification server and relevancy-matching server that can deliver to a ‘sandboxed’ mobile device targeted data based on content known to have been displayed on the television, despite the barriers to communication imposed by the sandbox.” *Id.* at 41.

Samba also contends that the purported claimed advance lies in sending the “relevant” content to a second device (i.e., a user’s mobile device) *through* a sandboxed application of a mobile device. When asked about how claim 1 achieves the bypassing of the sandboxed application, counsel stated that “it has the embedded object that the phone is going to process that is placed there by the relevancy matching server . . . and the content identification server is also there to go through that sandboxed application.” Oral Argument at 52:00–52:40.³ Specifically, Samba’s purported claimed advance lies in the following specific limitations of claim 1:

a mobile device capable of being associated with the television to: process an embedded object, constrain an executable environment in a security sandbox, and execute a sandboxed application in the executable environment . . . [;]

a content identification server to: process the fingerprint data from the television, and communicate the primary data from the fingerprint data to any of a number of devices with an access to an identification data of at least one of the television and an automatic content identification service of the television.

’356 patent at col. 52 ll. 3–16. We have, in other cases, noted that similar claims were directed to the abstract idea of “targeted advertising.” *See, e.g., Intellectual Ventures I LLC v. Cap. One Bank (USA)*, 792 F.3d 1363, 1369 (Fed. Cir. 2015); *Bridge & Post, Inc. v. Verizon Commc’ns, Inc.*, 778 F. App’x 882, 886 (Fed. Cir. 2019).

³ A recording of the Oral Argument is available at http://www.cafc.uscourts.gov/oral-argument-recordings?title=&field_case_number_value=19-1506&field_date_value=2019-05-11.

In the cases Samba relies on, this court determined that the respective claims were patent eligible because they were directed to a “specific improvement to the way computers operate.”⁴ More specifically, a common thread through all of the cited cases is a determination that the

⁴ See, e.g., *Enfish*, 822 F.3d at 1333, 1336–37 (claims “directed to a self-referential table for a computer database” functioned “differently than conventional database structures” and resulted in “faster searching” and “more effective storage”); *Visual Memory LLC, v. NVIDIA Corp.*, 867 F.3d 1253, 1256–59 (Fed. Cir. 2017) (claims “directed to an improved computer memory system” allowed “different types of processors to be installed with the [same] subject memory system without significantly compromising their individual performance”); *Finjan, Inc. v. Blue Coat Sys., Inc.*, 879 F.3d 1299, 1304–05 (Fed. Cir. 2018) (claims directed to “behavior-based scans” “employ[ed] a new kind of file that enables a computer security system to do things it could not do before” by linking a security profile identifying suspicious code in a downloadable object before making it available to a client device); *Core Wireless Licensing S.A.R.L. v. LG Elecs., Inc.*, 880 F.3d 1356, 1362 (Fed. Cir. 2018) (claims “directed to a particular manner of summarizing and presenting information in electronic devices” made websites easier to navigate on a small-screen device); *Uniloc USA, Inc. v. ADP, LLC*, 772 F. App’x 890, 897–98 (Fed. Cir. 2019) (claim “directed to the use of file packets with segments configured to initiate centralized registration of an application from an application server . . . enable[d] the further functionality of initiating on-demand registration of the application,” and the claim of the second patent “directed to a particular way of using a conventional application server . . . allow[ed] on[-]demand installation of an application incorporating preferences from two different sources by adding the application manager *and* configuration manager as additions to each application”).

claims were directed to an improvement in computer functionality. For example, in *Enfish*, this court determined that claims directed to an improvement in computer functionality “might not succumb to the abstract idea exception.” 822 F.3d at 1335 (citing *Alice*, 573 U.S. at 217–19). In that case, the “plain focus of the claims [wa]s on an improvement to computer functionality itself, not on economic or other tasks for which a computer is used in its ordinary capacity.” *Id.* at 1336. As will be discussed below, *Enfish* materially differs from the instant case.

Further, this court has explained that a relevant inquiry at *Alice* Step 1 is “whether the claims in the[] patent[] focus on a specific means or method that improves the relevant technology or are instead directed to a result or effect that itself is the abstract idea and merely invoke generic processes and machinery.” *McRO, Inc. v. Bandai Namco Games Am. Inc.*, 837 F.3d 1299, 1314 (Fed. Cir. 2016). Indeed, in response to Samba’s arguments, Alphonso asserts that Samba “failed to identify any language in the ’356 patent claims relating to overcoming the supposed communication barriers between a television and a mobile device.” Appellee’s Reply Br. at 4; *see also id.* at 5 (“[t]he claims do not explain in any way *how* the supposed communication barriers are overcome”); *see also id.* at 5 (“the claims do not describe *how* the purported ‘barriers to communication imposed by the sandbox’ are overcome”). As “reflected repeatedly in our cases,” a claim must “ha[ve] the specificity required to transform [the] claim from one claiming only a result to one claiming a way of achieving it” to avoid ineligibility. *SAP Am., Inc. v. InvestPic, LLC*, 898 F.3d 1161, 1167–68 (Fed. Cir. 2018) (collecting cases). As a result, a claim is ineligible if it “fail[s] to recite a practical way of applying an underlying idea . . . [and] instead [is] drafted in such a result-oriented way that [it] amount[s] to encompassing ‘the principle in the abstract’ no matter how implemented.” *Interval Licensing LLC v. AOL, Inc.*, 896 F.3d 1335, 1343 (Fed. Cir. 2018). All that is required at the

eligibility phase is that the claim itself “must identify ‘how’ that functional result is achieved by limiting the claim scope to structures specified at some level of concreteness, in the case of a product claim, or to concrete action, in the case of a method claim.” *Am. Axle & Mfg., Inc. v. Neapco Holdings LLC*, 967 F.3d 1285, 1302 (Fed. Cir. 2020). Here, Samba asserts that its invention allows devices on the same network to communicate where such devices were previously unable to do so. The asserted claims provide for how that is achieved only by stating that the mechanism used to achieve this communication is by piercing or otherwise overcoming a mobile device’s security sandbox. But the asserted claims do not at all describe how that result is achieved.

Even assuming the specification sufficiently discloses how the sandbox is overcome, the asserted claims nonetheless do not recite an improvement in computer functionality. According to the specification, the content identification server facilitates a communication session, which once established, “pierces” the sandboxed application via a “cross-site scripting technique, the appended header, the same origin policy exception, and/or the other mode of bypassing a number of (e.g., at least one) access controls of the security sandbox.” ’356 patent at col. 7 ll. 1–9 (patent reference numbers omitted). The only mechanisms recited in the specification used to bypass a number of access controls of the sandbox security do so by using a computer security vulnerability or relaxing a rule, which typically prevents access to a number of different sites, none of which are recited in the claims. *See id.*; *see also id.* at col. 12 ll. 6–10 (the “cross-site scripting technique” uses a “computer security vulnerability that enables an injection of a client-side script to bypass the number of access controls”); *id.* at col. 12 ll. 19–25 (the “same origin policy exception,” may be “a technique for relaxing a rule preventing an access to . . . a number of different sites”). All of this is done without intervention from the user of the client

device. *See id.* at col. 2 ll. 46–59. The asserted claims do not incorporate any such methods of piercing the sandbox.

With respect to claim 10, like claim 1, Samba alleges that the claimed advance is the rendering of targeted data to a user through the sandboxed application based on a relevancy factor, which includes a “category of a sandboxed application.”⁵ Oral Argument at 52:53–53:53, 55:06–57:44. When asked what “category of sandboxed application” meant, counsel responded that the category could be whether the mobile device was an “iPhone” or “Android.” *Id.* Thus, the relevancy-matching server “cause[s] a rendering of the targeted data to the user through the sandboxed application of the mobile device” by using the relevancy factor to first determine whether a user had an iPhone or Android. ’356 patent at col. 53 ll. 25–27. Again,

⁵ During arguments on summary judgment, Samba argued that claim 10 does not include or comprise a mobile device or television. The only requirement of the claims pertaining to the “television” and “mobile device” is that the claimed “relevancy matching server” is “communicatively coupled”—which the parties stipulated to mean “connected in a way that permits communication” with each of them. *See* J.A. 34; Appellant’s Br. at 6. While Samba argues that claim 10 does not require a mobile device, Samba also argues that the claimed advance of claim 10 is the piercing of a sandboxed application of the mobile device. There is a problem with the claimed advance including an element of the claim that Samba argues is not in fact required by the claim. In other words, the claimed advance of going through the sandboxed application of the mobile device necessarily requires the sandboxed application of the mobile device, but oddly a mobile device is not required by the claim according to Samba. Such an infirmity in the claim further favors concluding that claim 10 is patent ineligible.

claim 10 does not include how the targeted data is rendered. The specification provides some information as to how a sandboxed application may be bypassed by the establishment of a communication session, as described above, with the ultimate result being that a targeted advertisement “bypasses” a mobile device’s security sandbox without any intervention, or request made, by a user of that mobile device.

There is nothing in claims 1 or 10 that demonstrates an improvement to computer functionality. And, even assuming, as Samba argues, that the claimed advance is in the ability to pierce the sandbox of a mobile device, Samba has not demonstrated that this is something more than a mere use of a computer as a tool. The sandboxed application here is breached unbeknownst to the user through a “vulnerability” or “relaxation of the rules” that are conventionally in place to effectively prevent such a communication. In fact, Samba readily admits that the “problem” solved by the invention is “to provide relevant information across a sandboxed environment without requiring ‘installation, configuration, login, and/or user registration.’” Appellant’s Resp. & Reply Br. at 49; ’356 patent at col. 51 ll. 34–38. Therefore, the alleged technological improvement does nothing more than implement a computer to achieve the abstract idea of providing targeted advertising to the mobile device user.

Although Samba also asserts that its claimed invention results in televisions and mobile devices operating with respect to each other in a manner different from conventional televisions and mobile devices, Samba does not explain how that result improves the operability of these devices beyond providing a user with targeted content using generic processes and machinery. Samba’s claims merely improve the abstract idea of targeted advertising. Because we find that Samba’s asserted claims are not directed to an improvement of a technology or creation of a new computer

functionality, Samba's asserted claims are directed to an abstract idea.

B. Step 2

The district court did not reach Step 2 because it concluded that the claims were not directed to an abstract idea at Step 1. In response to Alphonso's cross-appeal, and its argument that there is nothing innovative about any of the computer processors or servers appearing in the claims, Samba argues that its claims are also eligible under Step 2 because they recite a specific, ordered combination of elements operating in unconventional ways, such that they override "their routine and conventional inability to share information with each other." Appellant's Resp. & Reply Br. at 52. In support of its arguments, Samba cites *DDR Holdings, LLC v. Hotels.com, L.P.*, 773 F.3d 1245 (Fed. Cir. 2014), and *BASCOM Global Internet Services, Inc. v. AT&T Mobility LLC*, 827 F.3d 1341 (Fed. Cir. 2016). Samba asserts that like the claims in the aforementioned cases, the claims of the '356 patent "specify the components or methods that permit the television and mobile device to operate in [an] unconventional manner, including the use of fingerprinting, a content identification server, a relevancy-matching server, and bypassing the mobile device security sandbox." Appellant's Br. at 53–54. In other words, the systems and methods of the '356 patent permit the "new and unconventional operation of mobile devices and televisions by intermediating their communication through components that, when functioning together, obtain information about content on the television and use it to identify content that can be provided to the mobile device despite its security sandbox." *Id.* at 55.

In *DDR Holdings*, the claimed invention solved the problem of allowing a website visitor to view a hyperlinked advertisement without being forced to leave the first website once the advertisement's hyperlink was activated. 773 F.3d. at 1258–59. The claims recited "an invention that is

not merely the routine or conventional use of the Internet.” *Id.* In *BASCOM*, this court determined that “an inventive concept can be found in non-conventional and non-generic arrangement of known, conventional pieces.” 827 F.3d at 1350 (explaining that the inventive concept rested in the installation of a filtering tool at a specific location, remote from the end-users, with customizable filtering features specific to each end user).

By contrast, here, sandbox security prevents, in part, internet-connected devices from communicating. *See* ’356 patent at col. 11 ll. 5–12 (“[t]he security sandbox may constrain what each of the number of applications is allowed to do. For example, the security sandbox may limit access to the networked, thereby making it difficult for the client device to find the networked device of the user and/or to obtain information directly from the network device. Such information may include what is currently playing on the networked device.”). The claimed invention simply seeks to undo that by “working around the existing constraints of the conventional functioning of television and mobile devices.” Appellant’s Resp. & Reply Br. at 53. However, such a “work around” or “bypassing” of a client device’s sandbox security does nothing more than describe the abstract idea of providing targeted content to a client device.

But even assuming the bypassing of mobile device security mechanisms had not been done before, there is nothing inventive disclosed in the claims that permits communications that were previously not possible. Indeed, the claims simply recite the use of generic features, as well as routine functions, to implement the underlying idea. *See Affinity Labs of Tex., LLC v. DIRECTV, LLC*, 838 F.3d 1253, 1262 (Fed. Cir. 2016). We have explained that an abstract idea is not patentable if it does not provide an inventive solution to a problem in implementing the idea. *Id.* at 1263. The claims here simply recite that the abstract idea will be implemented using conventional components and functions generic to the technology.

Nor does the “work-around” add more features that give rise to a Step 2 “inventive concept.” Processing an “embedded object” of claim 1 or rendering targeted data “through a sandboxed application of a mobile device” of claim 10 are not the kind of “additional features that provide practical assurance that the [claim] is more than a drafting effort designed to monopolize the [abstract idea] itself.” *Mayo*, 566 U.S. at 77–78. Finally, unlike in *BASCOM*, the claimed elements of Samba’s asserted claims comprise generic computing components—e.g., “servers”—arranged in a conventional manner and thus does not transform the claim into something other than the abstract idea. Therefore, Samba fails to demonstrate that claims 1 and 10 disclose patent eligible subject matter.

II

We turn next to Samba’s appeal of the Texas district court’s claim construction order construing disputed claim terms of the ’668 patent. As mentioned above, the asserted claims were construed by the Texas district court before the case was transferred to the California district court. Representative claim 1 of the ’668 patent recites in relevant part:

1. A system comprising: a networked device configured to: . . . automatically establish a **communication session** between the sandboxed application and the sandbox-reachable service through at least one of a cross-site scripting technique, an appended header, a same origin policy exception, and an other mode of bypassing a number of access controls of the security sandbox

’668 patent at col. 51 ll. 5–6, 31–37 (emphasis added).

The Texas district court construed “communication session” to mean a “period of time during which information is sent and received either directly or indirectly.” J.A. 44. According to the Texas district court, this

construction required information to be both “sent and received (i.e., bidirectional exchange)” during the session. J.A. 40. The district court did not adopt either party’s proposed construction but instead construed the limitation based on its own analysis of the evidence. J.A. 37–44.

Samba argues on appeal that the bidirectionality requirement of the Texas district court is too restrictive of an interpretation and is contrary to both the plain meaning of “communication session” and the intrinsic record. Specifically, Samba argues that the ordinary and customary meaning of “communication session” includes one-way communication and the ’668 patent discloses embodiments with one-way communication sessions. Alphonso argues that Samba’s reliance on the disclosure of “covert channels,” as being a “one-way communication,” mischaracterizes the specification because it improperly equates communicating to establish a communication session with communicating within the communication session. *See* J.A. 43. In other words, Alphonso argues that a covert channel simply enables a communication session but is not itself a communication session.

We review a district court’s ultimate claim construction and interpretation of intrinsic evidence *de novo*. *See Teva Pharms. USA, Inc. v. Sandoz, Inc.*, 574 U.S. 318 (2015). Claim construction requires a determination as to how a person of ordinary skill in the art would understand a claim term “in the context of the entire patent, including the specification. *See id.* (quoting *Phillips v. AWH Corp.*, 415 F.3d 1303, 1313 (Fed. Cir. 2005) (en banc)).

Based on a review of the ’668 patent and specification, we conclude that the district court’s construction is correct. J.A. 37–44. As the district court’s order makes clear, Samba’s desired construction, covering one-way communication, contradicts the specification because the section Samba points to does not actually refer to the same type of “communication session” recited in the claims. J.A. 43.

The district court also added that including “one-way” in the construction would improperly read “session” out of the claims, because Samba’s construction would then encompass any “communication.” *Id.* We agree.

It appears that the specification only graphically depicts “communication session” with a two-sided arrow connecting the client device and the networked device. ’668 patent Figs. 1–2, 4, 10, and 11. Moreover, all references to the *claimed* communication session, as between the networked device and the client device, describe this session as bidirectional. *See, e.g., id.* at col. 5 ll. 54–57, 64–65; col. 11 ll. 45–47. Therefore, one-way communication is not contemplated by the claim term “communication session.”

Given the specification, we conclude that a person of ordinary skill in the art would have understood “communication session” as requiring bidirectional communication. Thus, the Texas district court’s claim construction order is affirmed, and the California district court’s judgment of noninfringement based on this claim construction order and Samba’s stipulation remains unaffected.

CONCLUSION

As to Appeal No. 2019-2133, we reverse the California district court’s denial of Alphonso’s motion to dismiss because we conclude that claims 1, 10, 13, 18, and 20 of the ’356 patent are in fact patent ineligible. As to Appeal No. 2019-1506, we affirm the Texas district court’s claim construction of the asserted claims of the ’668 patent. Accordingly, we do not reach the California district court’s grant of summary judgment in Appeal No. 2019-1506.

REVERSED-IN-PART, AFFIRMED-IN-PART

COSTS

No Costs.