

**United States Court of Appeals
for the Federal Circuit**

CANFIELD SCIENTIFIC, INC.,
Appellant

v.

MELANOSCAN, LLC,
Appellee

2019-1927

Appeal from the United States Patent and Trademark
Office, Patent Trial and Appeal Board in No. IPR2017-
02125.

Decided: February 18, 2021

THOMAS LEE DUSTON, Marshall, Gerstein & Borun
LLP, Chicago, IL, argued for appellant. Also represented
by JULIANNE M. HARTZELL, JOHN J. LUCAS, SANDIP PATEL.

MARK D. GIARRATANA, McCarter & English, LLP, Hart-
ford, CT, argued for appellee. Also represented by KEVIN
REINER.

Before NEWMAN, DYK, and REYNA, *Circuit Judges*.
NEWMAN, *Circuit Judge*.

Canfield Scientific, Inc. (“Canfield”) appeals the decision of the U.S. Patent Trial and Appeal Board (“PTAB” or “Board”) on *inter partes* review (“IPR”) of U.S. Patent No. 7,359,748 (“the ’748 patent”) owned by Melanoscan, LLC. The ’748 patent “relates to the detection, diagnosis and treatment of skin cancer as well as other diseases and cosmetic conditions of the visible human.” ’748 patent, col. 1, ll. 22–24.

Canfield petitioned the Board for IPR of claims 1–8, 11, 30, 32–34, 46, and 51 of the ’748 patent, asserting unpatentability on the ground of obviousness. The Board ruled that all of the challenged claims are patentable.¹ Canfield appeals, arguing that the Board erroneously refused to consider arguments and evidence that Canfield presented, and that the Board misapplied the law of obviousness. We conclude that the Board erred in ruling that all the claims are patentable. That decision is reversed as to independent claims 1 and 51, and vacated and remanded as to the dependent claims in the petition.

BACKGROUND

The ’748 Patent

The ’748 patent is titled “Apparatus for Total Immersion Photography.” The apparatus, claimed as a “device,” is an enclosure fitted with cameras and lights arranged in a manner that “allows for the imaging of total or subtotal non-occluded body surfaces in order to detect health and cosmetic conditions and involves the measurement and analysis of an optically depicted image of a patient’s surfaces” ’748 patent, col. 1, ll. 7–11.

¹ *Canfield Scientific, Inc. v. Melanoscan LLC*, No. IPR2017-02125, 2019 WL 1407210 (P.T.A.B. Mar. 26, 2019) (“Board Op.”).

Figure 5 is an embodiment showing the device in cross-section and octagonal shape, with lights and cameras on all sides and the subject at the center:

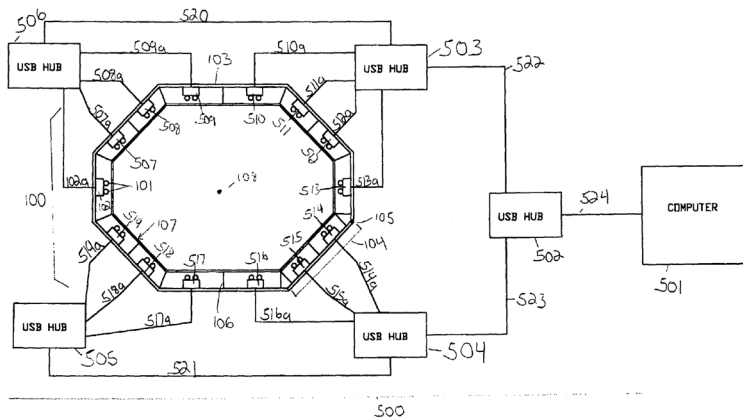

F.4 5

Figure 3 below is an alternate embodiment “utilizing a circular periphery” for the device:

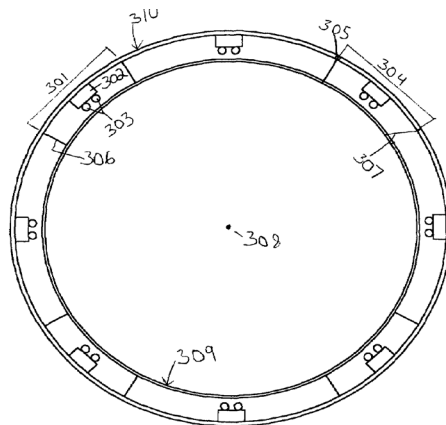

'748 patent, col. 18, l. 12. The '748 patent describes the arrangement of multiple cameras and lights “vertically spaced” and “laterally spaced” on “opposite sides of the centerline” and adjustable to obtain the desired images of “the

person or portion thereof,” placed within the enclosure. ’748 patent, col. 21, l. 63–col. 22, l. 25. Claims 1 and 51 are the only independent claims.

1. A device for the identification of maladies that effect [sic] human tissue comprising:

an enclosure configured to receive a person or portion thereof for imaging the person or portion thereof, wherein the enclosure defines a specified imaging position for placing the person or portion thereof within the enclosure for imaging, and the specified imaging position defines a centerline;

a plurality of imaging devices, wherein a plurality of the imaging devices are vertically spaced relative to each other, a plurality of the imaging devices are laterally spaced relative to each other, a plurality of the imaging devices are located on opposite sides of the centerline of the specified imaging position relative to each other, and each imaging device is located a predetermined distance relative to the specified imaging position; and

a plurality of light sources spaced relative to each other and peripheral to the plurality of imaging devices that illuminate the person or portion thereof located at the specified imaging position and generate refraction and reflectance light therefrom;

wherein each of said imaging devices generates an image of the illuminated person or portion thereof located at the specified imaging position, and defines respective coordinates and said respective predetermined distance relative to the specified imaging position, and defines a respective focal length and resolution information, allowing precise measurement of imaged features of the person or portion thereof located at the specified imaging position.

Id. Claim 51 is written in “means plus function” form for each limitation, but does not include limitations beyond those in claim 1.

The Board held claims 1 and 51 to be patentable, and did not decide separate patentability of the dependent claims, all of which contain limitations in addition to those in claims 1 and 51.

DISCUSSION

Standard of Review

Decisions of the U.S. Patent and Trademark Office (“PTO”) are reviewed on the standard of the Administrative Procedure Act (“APA”). *Dickinson v. Zurko*, 527 U.S. 150, 152 (1999). This standard applies to decisions of the PTAB. *Dell, Inc. v. Acceleron LLC*, 818 F.3d 1293, 1298 (Fed. Cir. 2016). In accordance with the APA, questions of law receive *de novo* review on appeal of the agency’s decision. *In re Gartside*, 203 F.3d 1305, 1311, 1316 (Fed. Cir. 2000).

Patentability on the ground of obviousness is a question of law, *see Belden, Inc. v. Berk-Tek LLC*, 805 F.3d 1064, 1073 (Fed. Cir. 2015), and receives *de novo* determination on appeal. Any underlying factual findings are reviewed on the APA standard of support by substantial evidence. *Id.* The substantial evidence inquiry requires examination of the “record as a whole, taking into account evidence that both justifies and detracts from an agency’s decision.” *Gartside*, 203 F.3d at 1312.

The factual inquiries in an obviousness determination comprise four primary factors: the scope and content of the prior art; the differences between the prior art and the claimed invention; the level of ordinary skill in the field of the invention; and objective considerations such as commercial success, long-felt need, and the failure of others. *Graham v. John Deere Co.*, 383 U.S. 1, 17 (1966). In determining obviousness, the adjudicator also considers aspects

such as the motivation to select and combine specified teachings of the prior art. *KSR Int'l Co. v. Teleflex, Inc.*, 550 U.S. 398, 400–01 (2007).

The Prior Art

Canfield cited five references in its petition for review—Voigt, Hurley, Crampton, Daanen, and Dye, outlined as follows:

Voigt

Holger Voigt and Richarda Classen, *Topodermatographic Image Analysis for Melanoma Screening and the Quantitative Assessment of Tumor Dimension Parameters of the Skin*, 75(4) CANCER 981 (1995) (“Voigt”)

Canfield applied Voigt to all the challenged claims, in various combinations with the references to Hurley, Crampton, Daanen, and Dye. Voigt describes an enclosure containing cameras and lights, for analyzing and measuring images on the skin of a patient. The device is illustrated in Figure 1, as a “schematic view”:

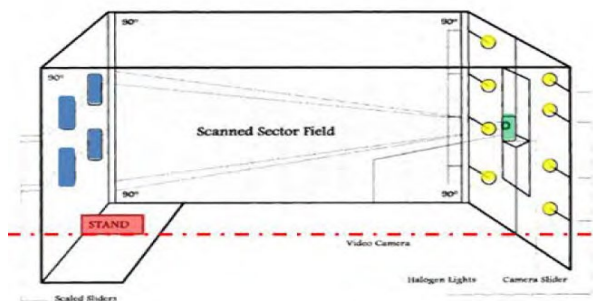

Fig. 1 (annotated by Canfield to show centerline)

Canfield states that “[t]he parties and the Board all agree that the only limitation of claim 1 . . . not disclosed by Voigt is the plurality of cameras spaced vertically, laterally, and on opposite sides of the centerline” within the Voigt

framework. Canfield Br. 9. Melanoscan states that since Voigt places the subject along a wall, the subject cannot be imaged from all sides, as required by the '748 patent.

The Board concluded that Canfield failed to show how combining Voigt with the other prior art references would make the claimed subject matter obvious.

Hurley

Jeffery D. Hurley et al., *Body Measurement System Using White Light Projected Patterns for Made-to-Measure Apparel*, 3131 PROC. SPIE [Society of Photo-Optical Instrumentation Engineers] 212 (1997) (“Hurley”)

Canfield in its petition applied Hurley, alone to claims 1–8, 11, 30, 33–34, and 46; in combination with Voigt to claims 1–5, 8, 11, 30, 33–34, 46, and 51; and in combination with Voigt and Daanen to claims 6 and 7.

Hurley shows a “non-contact body measurement system [] under development for use in making made-to-measure apparel, and for other applications related to body measurement. . . . The solution for calculating three-dimensional surface points of a human body from the camera images is described.” Hurley at 212. Hurley illustrates its device as follows:

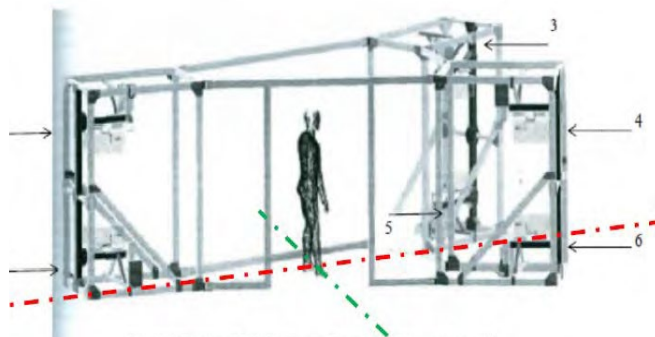

Fig. 2.1 (annotated by Canfield to show centerlines)

Hurley describes Figure 2.1 as a three-dimensional body-imaging system having six imaging sensors positioned on three towers, each tower bearing a lower and an upper sensor. Each imaging sensor consists of a light projector and a camera. Two towers are placed whereby the sensors image the front and side of the body, and the third tower is placed to image the back of the body.

The Board held all of the challenged claims patentable over combinations of Voigt, Hurley, and other references, finding that a person of ordinary skill in the art of imaging would not have been motivated to combine “the unmodified Voigt’s system with Hurley’s arrangement of imaging devices [for] . . . Voigt’s rear wall would have blocked the view of two rear-facing cameras, and Voigt’s horizontally adjustable sliders would have partially blocked the views of the remaining cameras.” Board Op. at *7.

Crampton

Stephen Crampton, *Avatar Kiosk*, WIPO International Publication No. WO 98/28908, July 2, 1998 (“Crampton”)

Canfield applied Crampton to claims 1–4, 8, 11, 30, and 33–34 in combination with Voigt, citing Crampton’s showing of vertically and horizontally placed cameras. Canfield also applied Crampton to claims 32 and 46 in combination with Voigt and Dye, claim 32 reciting USB ports and claim 46 reciting display devices as shown in Dye, *infra*.

Crampton shows an apparatus for imaging the surface of a person and creating an avatar of that person. *See* Crampton at 5 (“Avatars, also known as virtual humans, are used to represent a person in a virtual environment.”).

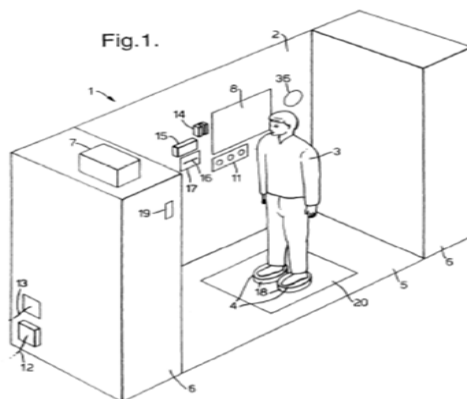
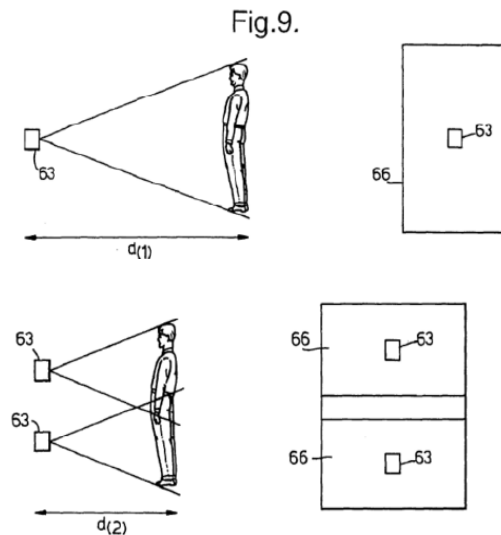

Figure 1 of Crampton above shows the person to be imaged placed in a kiosk having a central area with two footstands. The kiosk is fitted with multiple cameras and lights that surround the subject, and may also contain laser generators and flashlights.

Crampton states that image resolution is enhanced by the use of multiple cameras from various angles, as illustrated in Figure 9 of Crampton.



The Board found that a person of ordinary skill would not have been motivated to combine Crampton with Voigt with a reasonable expectation of success, in view of Voigt's placement of the subject along a wall.

Daanen

Hein A.M. Daanen & G. Jeroen van de Water, *Whole Body Scanners*, 19 DISPLAYS 111 (1998) ("Daanen")

Canfield applied the Daanen article, entitled "Whole Body Scanners," in combination with Voigt and Hurley, to claims 6 and 7. Claims 6 and 7 specify a third and fourth imaging array. Claim 6 is illustrative:

6. A device according to claim 1 wherein the plurality of imaging devices further includes:

a third imaging array spaced a predetermined distance relative to the specified imaging position, and laterally spaced relative to the first imaging array on an opposite side of the first imaging array relative to the second imaging array, wherein the third imaging array includes a plurality of third imaging devices vertically spaced relative to each other; and

a fourth imaging array spaced a predetermined distance relative to the specified imaging position, and laterally spaced relative to the second imaging array on an opposite side of the second imaging array relative to the first imaging array, wherein the fourth imaging array includes a plurality of fourth imaging devices vertically spaced relative to each other.

'748 patent, col. 22, ll. 49–64. Daanen describes the Vitronic® system that uses 16 to 24 cameras positioned around the subject, and states that the use of multiple cameras increases resolution and reduces shadowing effects. Canfield cites the statement in the '748 patent, that: "The

basis for the panel-camera array is to accurately capture the physiological attributes desired from the subject patient,” col. 4, ll. 39–40, and argues that Daanen teaches such an array surrounding the subject.

The Board found that Canfield “failed to set forth any persuasive reason why a person of ordinary skill in the art would have further modified the combination of Voigt and Hurley (which already would have included three sets of imaging devices) to further include the ‘arrangement of arrays’ of Daanen.” Board Op. at *13. The Board further found that Canfield’s “Petition is devoid of any persuasive explanation of how Voigt’s position framework could have been modified to simultaneously employ both Hurley’s arrangement of imaging sensors and Daanen’s arrangement of arrays, or of why a person of ordinary skill in the art would have had reason to simultaneously use both Hurley’s imaging sensors and Daanen’s arrays.” *Id.* The Board held that Canfield “failed to demonstrate by a preponderance of the evidence that claims 6 and 7 are unpatentable” as obvious. *Id.* at *14.

Dye

Thomas A. Dye, *Graphics System and Method for Rendering Independent 2D and 3D Objects*, WIPO International Publication No. WO 99/56249, Nov. 4, 1999 (“Dye”)

Canfield applied the Dye reference in combination with Voigt and Crampton to show obviousness of dependent claims 32 and 46 that recite the use of display devices to view two- and three-dimensional images and USB ports as “a preferred method for connecting a computer to one or more display devices.” Board Op. at *14. Dye illustrates its system as follows:

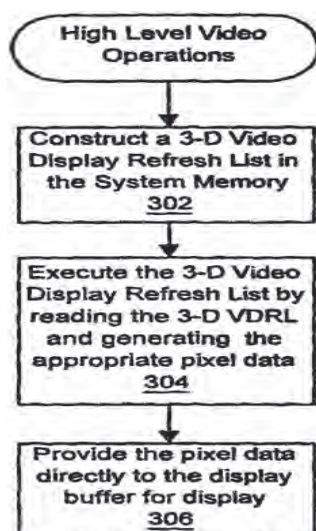

Fig. 5A

The Board did not discuss the dependent claims separately, on ruling that independent claims 1 and 51 are patentable.

Analysis

“A claimed invention is unpatentable if the differences between it and the prior art are such that the subject matter as a whole would have been obvious at the time the invention was made to a person having ordinary skill in the pertinent art.” *Tokai Corp. v. Easton Enters., Inc.*, 632 F.3d 1358, 1366 (Fed. Cir. 2011) (citing 35 U.S.C. § 103(a)).

Both Canfield and Melanoscan presented expert witnesses, who stated opposing views on the question of obviousness. For example, Canfield’s expert Dr. Hans-Peter Muller stated that “[t]he device disclosed in Voigt captured one side of a person’s torso . . . [and] [t]o increase the quantity and quality of skin-surface information, while avoiding the time and inconvenience of having to reposition the person being imaged, the camera, or both, one of ordinary skill in the art would have been motivated to make an obvious

modification to Voigt to employ the multiple cameras explicitly disclosed in Hurley [] to cover more body surface area without having to reposition the subject.” Muller Decl. ¶¶ 115, 117. Melanoscan’s expert Dr. van der Weide stated that there was no motivation to make this change with a reasonable expectation of success. van der Weide Decl. ¶¶ 56–58.

The Board agreed with Melanoscan’s expert, and held that a person of ordinary skill in the art of photo-imaging would not have been motivated to combine Voigt with the multi-camera systems of Hurley or Crampton or Daanen. The Board reasoned that “Voigt’s rear wall would have blocked the view of [Hurley’s] two rear-facing cameras, and Voigt’s horizontally adjustable sliders would have partially blocked the views of [Hurley’s] remaining cameras.” Board Op. at *7. The Board concluded:

The Petition thus fails to make the evidentiary showings required to demonstrate obviousness under 35 U.S.C. § 103 based on combining a modified version of Voigt’s system and Hurley[s] arrangement of imaging devices.

Id. The Board made no mention of the placement of the subject at the center of the multi-camera system as in Hurley and Crampton.

Claims 1 and 51 are not limited as to the location of the subject being imaged. Canfield argues that the combined teachings of the prior art would reasonably have suggested the subject matter of claims 1 and 51 to a person having ordinary skill in the field of the invention. *See Intelligent Bio-Sys., Inc. v. Illumina Cambridge Ltd.*, 821 F.3d 1359, 1367 (Fed. Cir. 2016) (considering whether the combination of elements from the prior art would produce the claimed subject matter).

Canfield argues that it would have been obvious to use known or obvious multiple imaging systems in known or

obvious enclosures having the object being imaged at the center of the enclosure. In Voigt the object is placed against a wall of the enclosure, and Hurley and Crampton show the object placed at the center of the enclosure. “The combination of familiar elements according to known methods is likely to be obvious when it does no more than yield predictable results.” *KSR*, 550 U.S. at 416.

Here, the references show various placements of the subject being imaged, in Voigt placed against a wall, and in Hurley, Crampton, and Daanen centrally placed within the framework. Voigt at 982; Hurley at 212; Crampton at 1, 6; Daanen at 113. The references show the cameras laterally and vertically spaced to each other about a centerline. Voigt at 981; Hurley at 212–13; Crampton at 11; Daanen at 115.

Claims 1 and 51 place the subject within the enclosure, as in the prior art, and place multiple cameras and lights within the enclosure, as in the prior art. We conclude that the subject matter described in claims 1 and 51 would have been obvious to a person of ordinary skill in the field of the invention. The Board’s ruling of patentability as to these claims is reversed.

Review of Dependent Claims

Although Canfield’s petition argued all of the challenged claims, the Board did not separately analyze the dependent claims, upon holding the independent claims to be patentable. Thus we vacate the Board’s decision as to dependent claims 2–8, 11, 30, 32–34, and 46, and remand for determination of patentability of these claims.

CONCLUSION

The ruling of patentability of claims 1 and 51 is reversed. The decision as to the other challenged claims is vacated; we remand for further proceedings as to these claims.

CANFIELD SCIENTIFIC, INC. v. MELANOSCAN, LLC

15

**REVERSED IN PART, VACATED IN PART, AND
REMANDED**

COSTS

No costs.