

United States Court of Appeals for the Federal Circuit

MEDTRONIC, INC.,
Appellant

v.

MARK A. BARRY,
Appellee

2017-1169, 2017-1170

Appeals from the United States Patent and Trade-
mark Office, Patent Trial and Appeal Board in Nos.
IPR2015-00780, IPR2015-00783.

Decided: June 11, 2018

MARK CHRISTOPHER FLEMING, Wilmer Cutler Picker-
ing Hale and Dorr LLP, Boston, MA, argued for appellant.
Also represented by ERIC FLETCHER; BRITTANY BLUEITT
AMADI, Washington, DC; RYAN NORTH MILLER, Fox Roth-
schild, LLP, Philadelphia, PA; JEFF E. SCHWARTZ, Wash-
ington, DC.

JOHN C. ALEMANNI, Kilpatrick Townsend & Stockton
LLP, Raleigh, NC, argued for appellee. Also represented
by SEAN PAUL DEBRUINE, Law Office of Sean DeBruine,
Menlo Park, CA.

Before TARANTO, PLAGER, and CHEN, *Circuit Judges*.

CHEN, *Circuit Judge*.

This is a consolidated appeal from two related decisions of the U.S. Patent and Trademark Office's Patent Trial and Appeals Board (Board) in *inter partes* review (IPR) proceedings. The Board concluded that the petitioner, Medtronic, Inc., had not proven that the challenged patent claims are unpatentable.

We affirm-in-part and vacate-in-part. Substantial evidence supports the Board's determination that the challenged claims would not have been obvious over two references: 1) U.S. Patent Application No. 2005/0245928 (the '928 Application); and (2) a book chapter which appears in *Masters Techniques in Orthopaedic Surgery: The Spine* (2d ed.) (MTOS). However, we vacate the Board's conclusion that certain other references, i.e., a video entitled "Thoracic Pedicle Screws for Idiopathic Scoliosis" and slides entitled "Free Hand Thoracic Screw Placement and Clinical Use in Scoliosis and Kyphosis Surgery" (Video and Slides), were not prior art because the Board did not fully consider all the factors for determining whether the Video and Slides were publicly accessible. We thus remand for further proceedings.¹

¹ The Supreme Court recently held in *SAS Institute Inc. v. Iancu*, 584 U.S. __ (2018), that the statute does not permit a partial institution leading to a partial final written decision. Because the final written decisions relating to this appeal do not address every ground raised in the petitions, we understand from the Board's recent guidance document, *Guidance on the impact of SAS on AIA trial proceedings* (April 26, 2018), <https://www.uspto.gov/patents-application-process/patent-trial-and-appeal-board/trials/guidance-impact-sas-aia->

BACKGROUND

Medtronic manufactures surgical systems and tools used in spinal surgeries. In February 2014, spine surgeon Dr. Mark Barry sued Medtronic for patent infringement in the Eastern District of Texas. Barry alleged that Medtronic's products infringed a group of Barry's patents, including U.S. Patent Nos. 7,670,358 (the '358 Patent) and 7,776,072 (the '072 Patent). Medtronic then petitioned for, and the Board instituted, IPR proceedings for all claims in both patents.

I. The '358 Patent

The '358 Patent is directed to a method for ameliorating aberrant spinal column deviation conditions, such as scoliosis. In addition to abnormal curvature of the spine, scoliosis may involve the rotation of vertebrae out of proper axial alignment. '358 Patent col. 2, ll. 51–56. The purported invention in the '358 Patent spreads corrective derotational (i.e., untwisting) forces across multiple vertebrae, thus reducing the risk of fracture during derotation. *Id.* at col. 3, ll. 15–25. The system includes pedicle screws implanted in the pedicle regions of vertebrae to which a surgeon, using a derotation tool, applies derotational forces. As a result, “the spinal column is manipulated en mass to achieve an over-all correction.” *Id.* at col. 3, ll. 37–42.

Figure 1 of the '358 Patent shows a “pedicle screw cluster derotation tool” engaged with a spinal column:

[trial](#), that it will consider the previously non-considered grounds on remand.

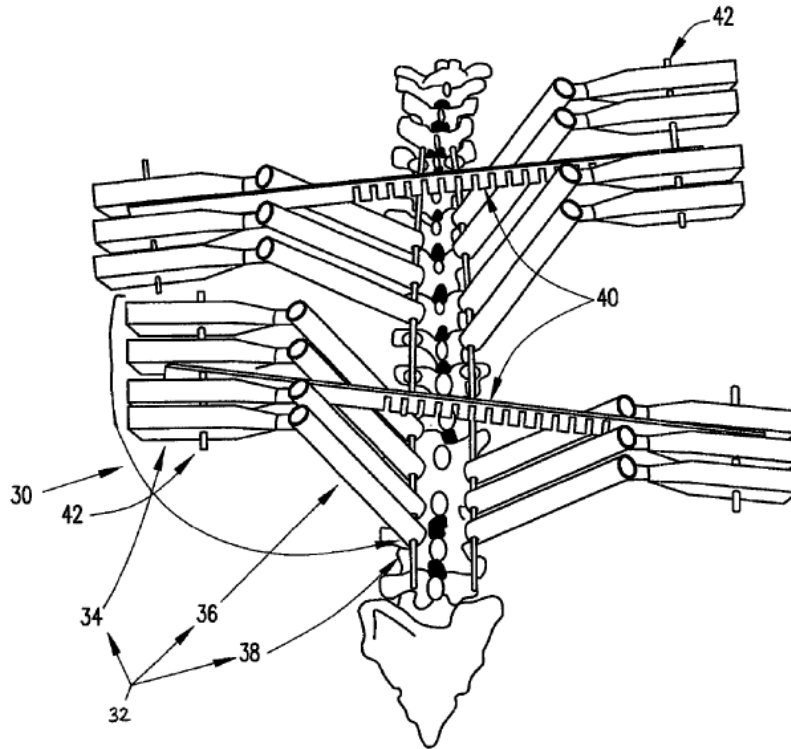

FIG. 1

As depicted in Figure 1, each pedicle screw cluster derotation tool (30) comprises a grouping of pedicle screw wrenches (32) connected by a linking member (42) to act in unison during use by a surgeon. *Id.* at col. 5, ll. 1–6. Each pedicle screw wrench (32) includes a handle (34) and a shaft (36) having a distal end (38) (“pedicle screw engagement member”), which is engaged with the pedicle screw. *Id.* at col. 5, ll. 12–18.

By grasping the linked handles as a group (“handle means”), the surgeon can apply derotational forces during a spinal corrective procedure. *Id.* at col. 3, ll. 48–54. “[A]s manipulative forces are applied to the handle means . . . [such] forces are transferred and dispersed simultaneously among the engaged vertebrae.” *Id.* at col. 3, ll. 56–59.

Claim 1 of the '358 Patent is representative of the challenged claims for purposes of this appeal:

1. A method for aligning vertebrae in the amelioration of aberrant spinal column deviation conditions comprising the steps of:

selecting a first set of pedicle screws, said pedicle screws each having a threaded shank segment and a head segment;

selecting a first pedicle screw cluster derotation tool, said first pedicle screw cluster derotation tool having first handle means and a first group of pedicle screw engagement members which are mechanically linked with said first handle means, each pedicle screw engagement member being configured for engaging with, and transmitting manipulative forces applied to said first handle means to said head segment of each pedicle screw of said first set of pedicle screws,

implanting a each [sic] pedicle screw in a pedicle region of each of a first group of multiple vertebrae of a spinal column which exhibits an aberrant spinal column deviation condition;

engaging each pedicle screw engagement member respectively with said head segment of each pedicle screw of said first set of pedicle screws; and

applying manipulative force to said first handle means in a manner for simultaneously engaging said first group of pedicle screw engagement members and first set of pedicle screws and thereby in a single motion simultaneously rotating said vertebrae

of said first group of multiple vertebrae in which said pedicle screws are implanted to achieve an amelioration of an aberrant spinal column deviation condition;

selecting a first length of a spinal rod member; wherein one or more of said pedicle screws of said first set of pedicle screws each includes:

a spinal rod conduit formed substantially transverse of the length of said pedicle screw and sized and shaped for receiving passage of said spinal rod member therethrough; and

spinal rod engagement means for securing said pedicle screw and said spinal rod member, when extending through said spinal rod conduit, in a substantially fixed relative position and orientation;

extending said first length of said spinal rod member through said spinal rod conduits of one or more of said pedicle screws of said first set of pedicle screws; and

after applying said manipulative force to said first handle means, actuating said spinal rod engagement means to secure said vertebrae in their respective and relative positions and orientations as achieved through application of said manipulative force thereto.

'358 Patent, claim 1 (emphasis added). The issues raised in Medtronic's appeal concern the italicized language of claim 1 set out above. We will refer to the language as the "Simultaneously Rotating" limitation.

II. The '072 Patent

The '072 Patent is a continuation-in-part of the application that led to the '358 Patent and shares substantially the same specification.

Claim 1 of the '072 Patent is representative of the challenged claims of this patent, and, like Claim 1 of the '358 Patent, recites a derotation tool that engages with pedicle screws:

1. A system for aligning vertebrae in the amelioration of aberrant spinal column deviation conditions comprising:

a first set of pedicle screw, each pedicle screw having a threaded shank segment and a head segment; and

a first pedicle screw cluster derotation tool, said first pedicle screw cluster derotation tool having a first handle means for facilitating simultaneous application of manipulative forces to said first set of pedicle screws and a first group of three or more pedicle screw engagement members which are mechanically linked with said first handle means, said first handle means configured to move simultaneously each pedicle screw engagement member;

wherein each pedicle screw engagement member is configured to engage respectively with said head segment of each pedicle screw of said first set of pedicle screws; and wherein each pedicle screw engagement member is configured to transmit manipulative forces applied to said first handle means to said head segment of each pedicle screw of said first set of pedicle screws.

'072 Patent, claim 1 (emphasis added). We will refer to the italicized claim language as the “Derotation Tool” limitation.

III. Relevant Prior Art

Medtronic submitted the following prior art references relevant to the issues raised in this appeal: (1) the '928 Application; (2) MTOS; and (3) Video and Slides.

A. '928 Application

The '928 Application is common to all of Medtronic's asserted grounds of obviousness that we consider on appeal. J.A. 1789–1805. The '928 Application discloses a tool (“the '928 device”) for displacing vertebrae, relative to each other, during spinal surgery. J.A. 1789 at Abstract, J.A. 1798 at ¶ 8. “Displacement” in the '928 Application refers to the movement of two vertebrae either closer together (compression) or farther apart (distraction). The '928 Application discloses how a surgeon makes small incisions in the skin that are just large enough to insert the portions of the '928 device that engage pedicle screws implanted in the vertebrae. J.A. 1801–02 at ¶ 46. The skin remains intact between these incisions, allowing the procedure to remain minimally invasive. J.A. 1799 at ¶ 24. Unlike the '358 or the '072 Patents, the surgical technique described in the '928 Application does not involve a large incision between the vertebrae that exposes substantial portions of the spine. *See id.*; J.A. 1798 at ¶ 6.

B. MTOS

MTOS is a book chapter describing techniques of using pedicle screws in the thoracic and lumbar spine. J.A. 2546–61. In one technique taught in MTOS, a surgeon places “correcting posts” on pedicle screws on both the convex and concave sides of the spinal curve and uses these posts to apply manipulative force in a spinal derotation procedure. J.A. 2557. MTOS describes performing

multiple “apical vertebral derotation” (AVD) maneuvers to derotate the spine but does not explicitly disclose manipulating multiple posts simultaneously as part of the AVD maneuvers. J.A. 2557–60.

C. The Video and Slides

Medtronic distributed a video demonstration and a related slide presentation to spinal surgeons at various industry meetings and conferences in 2003. J.A. 1719–57. These video and slide sets depict derotation surgeries that use pedicle screws and other instrumentation to correct scoliosis. J.A. 1467–72. The Video consists of a narrated derotation surgery performed in 2001 by Dr. Lenke, who testified as Medtronic’s expert in this case. J.A. 1467–70. The Slides include information about the use of pedicle screws in derotation surgeries, including numerous pictures from surgeries performed and x-rays of pre-operative and post-operative spines. J.A. 1735–49. The Board found that the Video and Slides, although presented at three different meetings in 2003, were not publicly accessible and therefore were not “printed publications,” in accordance with 35 U.S.C. § 102.² As a result, the Board, in its final decisions, refused to consider these materials as prior art in its evaluation of the ’358 and ’072 Patents.

DISCUSSION

We review the Board’s legal conclusions de novo and its factual findings for substantial evidence. *Ethicon Endo-Surgery, Inc. v. Covidien LP*, 812 F.3d 1023, 1028 (Fed. Cir. 2016). Substantial evidence is “such relevant evidence as a reasonable mind might accept as adequate to support a conclusion.” *In re Applied Materials, Inc.*,

² Because the claims at issue in this case have effective filing dates before March 16, 2013, we apply the pre-AIA § 102.

692 F.3d 1289, 1294 (Fed. Cir. 2012) (quoting *Consol. Edison Co. of N.Y. v. NLRB*, 305 U.S. 197, 229 (1938)). We have jurisdiction over these appeals under 28 U.S.C. § 1295(a)(4) (2012).

I. The '358 Patent—Obviousness

For the '358 Patent, the Board instituted *inter partes* review of claims 1–5. Method Claim 1 is the sole independent claim, and the primary focus of the parties' contentions concerns whether the prior art discloses claim 1's "Simultaneously Rotating" limitation:

applying manipulative force to said first handle means in a manner for simultaneously engaging said first group of pedicle screw engagement members and first set of pedicle screws and *thereby in a single motion simultaneously rotating said vertebrae* of said first group of multiple vertebrae in which said pedicle screws are implanted to achieve an amelioration of an aberrant spinal column deviation condition;

'358 Patent, claim 1 (emphasis added). As explained below, substantial evidence supports the Board's findings underlying its conclusion that Medtronic failed to prove that the challenged claims would have been obvious over the combination of the '928 Application and MTOS.

A. Obviousness over the '928 Application

Medtronic first argues that the '928 Application alone made it obvious for a spine surgeon to use its displacement device to rotate multiple vertebrae simultaneously. The Board, however, found that the '928 Application fails to disclose the "Simultaneously Rotating" limitation because the operation of the '928 device requires multiple motions, as opposed to a single motion, and results in compression or distraction of the vertebrae, as opposed to derotation. J.A. 20. The specification of the '928 Applica-

tion supports the Board’s finding that this claimed step is missing from the reference.

Figure 11 depicts a preferred embodiment of the ’928 device:

FIG. 11

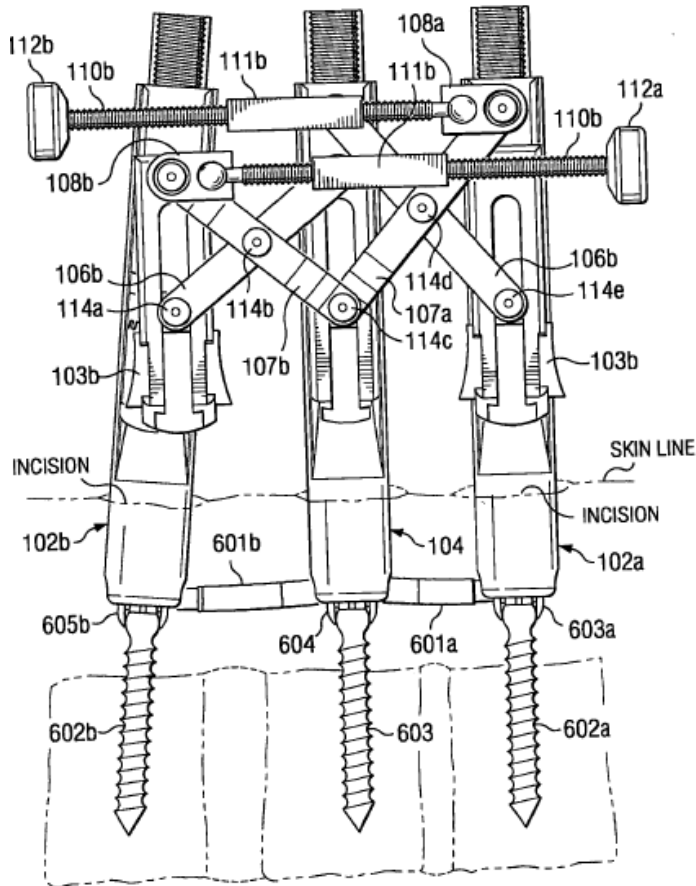

As noted, small incisions in the skin are made above each individual vertebra to insert guide tubes that engage with the pedicle screws. As seen in Figure 11, when knob 112b is turned, cross action members 106b and 107b move, causing guide tube 102b to be displaced relative to guide tube 104, which remains stationary. Adjusting knob 112a causes the same action regarding guide tubes 102a and 104. As the Board observed, the designed use in

the '928 Application thus requires multiple motions to apply force to more than one guide tube relative to another. J.A. 20. Those motions result in compression and distraction of vertebrae, i.e., drawing the vertebrae closer together or farther apart along the axis of the spine. *Id.* In contrast, all of the challenged claims require a handle means to apply “simultaneous” force to a first set of pedicle screws to *rotate* the vertebrae. Therefore, substantial evidence supports the Board’s finding that the '928 Application alone does not disclose the “Simultaneously Rotating” limitation.

Medtronic argues that the '358 Patent claims nevertheless would have been obvious in light of the '928 Application because, once the '928 device’s guide tubes are inserted through the patient’s skin and engaged with the pedicle screws, a surgeon could simply grab the device with one hand and push or pull it—just as one may push or pull a doorknob, in addition to turning it. Citing paragraph 55 of the '928 Application, Medtronic points out that the '928 Application discloses an embodiment that involves applying perpendicular force to the instrument. Medtronic also cites the testimony of its expert, Dr. Lenke, to explain that, “[i]f a surgeon was to use the tool disclosed in the '928 Application to apply this perpendicular force in a downward direction, it would naturally cause a derotation of the vertebrae.” J.A. 1476.

The Board observed that paragraph 55 of the '928 Application does not mention pulling, pushing, or twisting the '928 device. J.A. 29. It found that paragraph 55 “appears to disclose pressing downward or upward from the posterior of the patient and then applying distraction by turning the knobs of the tool.” *Id.* The Board, however, rejected Dr. Lenke’s opinion that the application of the perpendicular force would necessarily result in a rotation of the vertebrae. J.A. 30. Rather, it credited the testimony of Barry’s expert, Dr. Yassir, who opined that any amount of rotation would be minimal and that using the

'928 device to rotate vertebrae as claimed would likely introduce, rather than correct, spinal deformities. *Id.* After considering all the evidence, the Board concluded that, although the '928 Application extensively discusses compression and distraction, it says nothing about seeking to rotate vertebrae—much less mention derotating vertebrae through simultaneous application of force. *Id.*

We discern no error in the Board's determination. There is no disclosure in the '928 Application of scoliosis, scoliotic curvature, or twisting of the spine. J.A. 28. Nor is there any mentioning of derotating the spine or any bone structure. The embodiments of the '928 Application instead describe "a device that may perform compression and distraction interchangeably without the need for having separate compression and distraction devices." J.A. 1798 ¶ 8. The Board reasonably found no persuasive evidence that the '928 Application teaches a derotational use for its compression/distraction device or that it would have been obvious to use such a device to "in a single motion simultaneously rotat[e]" multiple vertebrae "to achieve an amelioration of an aberrant spinal column deviation condition," as required by the claims of the '358 Patent. J.A. 30–31.

B. Obviousness over the Combination of the '928 Application and MTOS

Alternatively, Medtronic argues that MTOS discloses the "Simultaneously Rotating" limitation and that one of ordinary skill in the art would have been motivated to combine the teachings of the '928 Application with MTOS. Specifically, Medtronic argues that MTOS discloses the application of manipulative forces to a group of correcting posts that are grasped by the surgeon in a manner for simultaneously engaging a first group of pedicle screws. The Board, however, rejected this characterization and pointed out that Medtronic and its expert failed to cite to any particular passage or figures from MTOS that "explic-

itly disclose[] the simultaneous application of manipulative force.” J.A. 35. This observation is consistent with MTOS’s disclosure. J.A. 2557–60.

Further, the Board identified significant differences between the ’928 Application and MTOS that undercut Medtronic’s arguments that the references were readily combinable by the skilled artisan. J.A. 37–38. For example, the ’928 Application discloses a “displacement device . . . that minimizes the incision made on a patient in order to perform displacement (compression and/or distraction) of bony structures.” J.A. 1798 ¶ 8. In contrast, MTOS teaches “open” surgical procedures requiring an invasively-large incision in the skin along the length of the spinal column. J.A. 2557–60.

The Board also reasonably found that neither reference discloses or suggests a device or system with a “handle means” that performs the simultaneous rotational functions as recited by the challenged claims. Specifically, MTOS discloses pedicle screw engagement members, but lacks a single “handle means,” and does not disclose causing a simultaneous rotation of vertebrae in a single motion. J.A. 32, 37. And the ’928 Application only discloses a tool with linked members and knobs that are used to achieve controlled distraction and compression of vertebrae. J.A. 30. Substantial evidence supports the Board’s finding that the tools in the ’928 Application and MTOS have different uses in different contexts in that MTOS addresses a relatively more invasive surgery than the ’928 Application. It also supports the Board’s conclusion that Medtronic had not demonstrated by a preponderance of the evidence that it would have been obvious to a person of ordinary skill to modify either the tool disclosed in the ’928 Application or the pedicle screw engagement members disclosed in MTOS in a manner to achieve the “Simultaneously Rotating” claim element.

II. The '072 Patent—Obviousness

In the IPR of the '072 Patent, Medtronic largely relied on the same prior art references it used to challenge the claims of the '358 Patent. The Board's analysis of the patentability of the '072 Patent claims, claims 1–4, focused on the “Derotation Tool” limitation:

a first pedicle screw cluster derotation tool, said first pedicle screw cluster derotation tool having a first handle means for facilitating simultaneous application of manipulative forces to said first set of pedicle screws and a first group of three or more pedicle screw engagement members which are mechanically linked with said first handle means, said first handle means configured to move simultaneously each pedicle screw engagement member.

'072 Patent, claim 1. The Board noted that the claim language of the '072 Patent was very similar to that of the '358 Patent and that the parties' arguments were largely the same. J.A. 59–60. It also acknowledged that the challenged claims in the '072 Patent did not include the limitation “in a single motion simultaneously rotating vertebrae.” *Id.* Rather, a “fundamental issue” was whether it would have been obvious to combine the features of the prior art to arrive at a “derotation tool” with a handle means that facilitates, per the claims, simultaneous application of forces to pedicle screws mechanically linked through engagement members. J.A. 60. After reviewing the prior art and considering the expert testimony from both parties, the Board reasonably concluded that Medtronic had failed to demonstrate that the challenged claims are unpatentable.

Medtronic argues that the Board improperly interpreted the claims of the '072 Patent to require rotation, and that the Board's analysis of obviousness is therefore flawed. We disagree. While the Board referred to the

'358 Patent, it explicitly recognized that the claim language in the '072 Patent is different. It then analyzed whether Medtronic had proven that the prior art rendered the '072 Patent claims obvious as written and found that Medtronic failed to do so.

Further, Medtronic's contention on appeal that derotation has no relevance to claims 1 and 2 of the '072 Patent is unpersuasive. Notably, the challenged claims all require a "derotation tool." Moreover, Medtronic itself argued in its petition challenging the '072 Patent that each of the prior art references discloses a tool or surgical procedure for performing a derotation of the vertebrae. *See* J.A. 7018–21. The Board analyzed whether the prior art disclosed rotation because that was what Medtronic argued as a basis for the motivation to combine the references.

We see no error in the Board's analysis of the cited references or its decision to credit the testimony of the patent owner's expert over that of Medtronic's expert that the references did not disclose a derotation tool, as claimed. For these reasons, we conclude that substantial evidence supports the Board's determination that a person of ordinary skill would not have understood the combination of the '928 Application and MTOS to disclose the "Derotation Tool" limitation.

III. Whether the Board Erred in Concluding that the Video and Slides Were Not Accessible to the Public

In the IPR proceedings, Medtronic challenged the claims of the '358 Patent and '072 Patent, among other grounds, on the basis that they would have been obvious over the combination of the '928 Application, MTOS, and the Video and Slides. J.A. 6, 46.³ The Board, in its final

³ For claims 3 and 4 of the '072 Patent, Medtronic also relied on U.S. Patent Application No. 2005/0033291

written decisions, found that the Video and Slides were not prior art. J.A. 13, 54. On appeal, the parties dispute whether the Video and Slides constitute printed publications within the meaning of 35 U.S.C. § 102(b).

A CD containing the Video was distributed at three separate programs in 2003: (1) a meeting of the “Spinal Deformity Study Group” (SDSG) in Scottsdale, Arizona, on April 10–13, 2003 (the Scottsdale program); (2) the Advanced Concepts in Spinal Deformity Surgery meeting in Colorado Springs, Colorado, on May 18–19, 2003 (the Colorado Springs program); and (3) the Spinal Deformity Study Symposium meeting in St. Louis, Missouri, on November 13–15, 2003 (the St. Louis program). J.A. 2651–52, 2667–67. Binders containing relevant portions of the Slides were also distributed at the Colorado Springs and St. Louis programs. J.A. 2667, 4633.

The earliest of the three 2003 programs, the Scottsdale program, was limited to SDSG members. J.A. 5904–09. Medtronic’s witness, David Poley, described SDSG as “a gathering of experts within the field of spinal deformity.” J.A. 5904. About 20 SDSG members attended the Scottsdale program. J.A. 2651. The other two programs were open to other surgeons. J.A. 2668. Medtronic sponsored these programs as medical education courses. J.A. 2666. Approximately 20 and 55 surgeons attended the Colorado Springs and St. Louis programs, respectively. J.A. 2667–68, 4633.

(the '291 Application) as a prior art reference for its obviousness challenge. In the final written decision for the '072 Patent, the Board declined to consider whether the '928 Application, the '291 Application, and MTOS separately rendered obvious claims 3 and 4 after finding that the '291 Application was not relevant to the disputed “Derotation Tool” limitation. J.A. 81.

Medtronic argues that the Board committed legal error in concluding that the Video and Slides were not sufficiently accessible to the public. According to Medtronic, the Board’s sole basis for this conclusion rested on its faulty assumption that the materials were distributed only to members of the SDSG. *See* J.A. 12–13. Medtronic points out two problems with this assumption. First, it argues that the Board improperly ignored evidence that the Video and Slides were distributed at programs that were not limited to SDSG members. Second, Medtronic contends that, even if the assumption were correct, a reference need only be accessible to the “interested public” to satisfy the public accessibility requirement, and that, members of the SDSG fall squarely within that category.

According to Barry, the Board correctly found that “members of the Spinal Deformity Study Group, who received the Video and Slides, were experts voted into membership by an executive board based on their qualifications and ability to conduct research.” J.A. 12. Because the slides were only available to experts who are part of a group limited to members only, and not those of ordinary skill, Barry argues that the Video and Slides were not publicly accessible to ordinarily skilled artisans.

Whether a reference qualifies as a “printed publication” is a legal conclusion based on underlying factual determinations. *Suffolk Techs., LLC v. AOL Inc.*, 752 F.3d 1358, 1364 (Fed. Cir. 2014) (citation omitted). “The ‘printed publication’ provision of § 102(b) ‘was designed to prevent withdrawal by an inventor . . . of that which was already in the possession of the public.’” *Bruckelmyer v. Ground Heaters, Inc.*, 445 F.3d 1374, 1378 (Fed. Cir. 2006) (alteration in original) (quoting *In re Wyer*, 655 F.2d 221, 226 (C.C.P.A. 1981)); *see Blue Calypso, LLC v. Groupon, Inc.*, 815 F.3d 1331, 1348 (Fed. Cir. 2016) (“This rule is grounded on the principle that once an invention is in the public domain, it is no longer patentable by anyone.” (internal quotation marks and citations omitted)).

Medtronic, as the patent challenger, bears the burden of establishing that a particular document is a printed publication. *See Blue Calypso*, 815 F.3d at 1350–51 (holding that petitioner failed to carry its burden of proving public accessibility of the allegedly invalidating reference).

The determination of whether a document is a “printed publication” under 35 U.S.C. § 102(b) “involves a case-by-case inquiry into the facts and circumstances surrounding the reference’s disclosure to members of the public.” *In re Klopfenstein*, 380 F.3d 1345, 1350 (Fed. Cir. 2004). “Because there are many ways in which a reference may be disseminated to the interested public, ‘public accessibility’ has been called the touchstone in determining whether a reference constitutes a ‘printed publication’ bar under 35 U.S.C. § 102(b).” *Blue Calypso*, 815 F.3d at 1348 (quoting *In re Hall*, 781 F.2d 897, 898–99 (Fed. Cir. 1986)). “A reference will be considered publicly accessible if it was ‘disseminated or otherwise made available to the extent that persons interested and ordinarily skilled in the subject matter or art exercising reasonable diligence[] can locate it.’” *Id.* (quoting *Kyocera Wireless Corp. v. Int’l Trade Comm’n*, 545 F.3d 1340, 1350 (Fed. Cir. 2008)).

The issue of a reference’s public accessibility often arises in the context of references stored in libraries. In such cases, we generally inquire whether the reference was sufficiently indexed or cataloged. *Id.* Here, we encounter a different question: whether the distribution of certain materials to groups of people at one or more meetings renders such materials printed publications under § 102(b). We have stated that a printed publication “need not be easily searchable after publication if it was sufficiently disseminated at the time of its publication.” *Suffolk Techs.*, 752 F.3d at 1365 (concluding that an electronic newsgroup post was sufficiently disseminated where the newsgroup was populated by those of ordinary skill in the art and “dialogue with the intended audience

was the entire purpose of the newsgroup postings,” even though the post was non-indexed and non-searchable). The parties here do not allege that the Video and Slides were stored somewhere for public access after the conferences. Thus, the question becomes whether such materials were sufficiently disseminated at the time of their distribution at the conferences. A survey of previous cases involving distribution of materials at meetings provides factors relevant to this case.

For example, in *Massachusetts Institute of Technology v. AB Fortia (MIT)*, a paper that was orally presented at a conference to a group of cell culturists interested in the subject matter was considered a “printed publication.” 774 F.2d 1104, 1109 (Fed. Cir. 1985). In that case, between 50 and 500 persons having ordinary skill in the art were told of the existence of the paper and informed of its contents by the oral presentation. *Id.* at 1109. We took note that the document itself was disseminated without restriction to at least six persons. *Id.* at 1108–09. Thus, whether the copies were freely distributed to interested members of the public was a key consideration in our analysis.

We highlighted a similar consideration concerning expectations of confidentiality as part of the public-accessibility inquiry in *Cordis Corp. v. Boston Scientific Corp.*, 561 F.3d 1319 (Fed. Cir. 2009). There, the issue pertained to whether a set of research papers distributed by a doctor to certain colleagues and two commercial entities rendered the documents printed publications. *Id.* at 1333. We concluded that such documents were not publicly accessible. *Id.* at 1333–35. As for the doctor’s presentation of his work to his university and hospital colleagues, we noted that the record contained clear evidence that the academic norms gave rise to an expectation that disclosures would remain confidential. *Id.* at 1334. Likewise, we held that the doctor giving the research papers to two companies in an attempt to commer-

cialize the technology did not make the documents accessible to the public. *Id.* In so concluding, we emphasized the importance of an expectation of confidentiality between the doctor and each of the two commercial entities. *Id.* The mere fact that there was no legal obligation of confidentiality was insufficient by itself to show that the doctor's expectation of confidentiality was unreasonable. *Id.* at 1335.

In re Klopfenstein is also instructive in its identification of the relevant factors. 380 F.3d 1345 (Fed. Cir. 2004). The reference in dispute in that case was a printed slide presentation that was displayed prominently for three days at a conference to a wide variety of participants. *Id.* at 1350. The reference was shown with no stated expectation that the information would not be copied or reproduced by those viewing it. *Id.* But copies were never distributed to the public and never indexed. *Id.* Under such a scenario, we identified the relevant factors to include: (1) "the length of time the display was exhibited," (2) "the expertise of the target audience" (to determine how easily those who viewed the material could retain the information), (3) "the existence (or lack thereof) of reasonable expectations that the material displayed would not be copied," and (4) "the simplicity or ease with which the material displayed could have been copied." *Id.* After reviewing these factors, we determined that the reference was sufficiently publicly accessible to count as a "printed publication" for the purposes of § 102(b). *Id.* at 1352.

These decisions illustrate some common considerations about materials that are distributed at meetings or conferences. As relevant to this case, the size and nature of the meetings and whether they are open to people interested in the subject matter of the material disclosed are important considerations. Another factor is whether there is an expectation of confidentiality between the distributor and the recipients of the materials. Even if

there is no formal, legal obligation of confidentiality, it still may be relevant to determine whether any policies or practices associated with a particular group meeting would give rise to an expectation that disclosures would remain confidential.

The record does not show that the Board fully considered all of the relevant factors. As a threshold matter, the Board did not address the potentially-critical difference between the SDSG meeting in Arizona and the programs in Colorado Springs and St. Louis, which were not limited to members of the SDSG but instead were attended by at least 75 other surgeons, collectively. J.A. 2668. Also, Medtronic's expert, Dr. Lenke, testified that the materials were distributed without restrictions at the Colorado Springs and St. Louis programs. J.A. 1467–68, 3002. Although the Board found that disclosure to a small group of experts in the members-only SDSG meeting was insufficient to compel a finding that the Video and Slides were publicly available, its analysis was silent on the distribution that occurred in the two non-SDSG programs.

Further, even if the Board were correct in its assumption that Medtronic only gave the Video and Slides to the SDSG members, it did not address whether the disclosures would remain confidential. The Board found that SDSG members were experts voted into membership by an executive board based on their qualifications and research, but the relatively exclusive nature of the SDSG membership is only one factor in the public accessibility analysis. It may be relevant, for example, to consider the purpose of the meetings and to determine whether the SDSG members were expected to maintain the confidentiality of received materials or would be permitted to share or even publicize the insights gained and materials collected at the meetings. *See, e.g.*, J.A. 4153 (stating that the materials were distributed at the SDSG meeting without restriction or obligation of confidentiality).

Accordingly, whether dissemination of the Video and Slides to a set of supremely-skilled experts in a technical field precludes finding such materials to be printed publications warrants further development in the record. The expertise of the target audience can be a factor in determining public accessibility. See *In re Klopfenstein*, 380 F.3d at 1350–51 (“The expertise of the intended audience can help determine how easily those who viewed it could retain the displayed material.”). But this factor alone is not dispositive of the inquiry. Distributing materials to a group of experts, does not, without further basis, render those materials publicly accessible or inaccessible, simply by virtue of the relative expertise of the recipients. The nature of those meetings, as well as any restrictions on public disclosures, expectations of confidentiality, or, alternatively, expectations of sharing the information gained, can bear important weight in the overall inquiry.

For these reasons, we vacate the Board’s finding that the Video and Slides are not printed publications and remand for further proceedings consistent with this opinion.

CONCLUSION

We affirm the Board’s conclusions that the ’928 Application and MTOS, separately or in combination, do not render obvious the challenged claims of the ’358 and ’072 patents. But we vacate the Board’s determination that the Video and Slides do not qualify as prior art and remand for further proceedings. On remand, the Board shall determine, consistent with this opinion, whether the Video and Slides are publicly-accessible publications for prior art purposes. If not, then the inquiry ends. Otherwise, the Board will need to consider the Video and Slides as prior art and decide whether these references, in combination with the ’928 Application and MTOS, render

obvious claims 1–5 of the '358 Patent and claims 1–4 of the '072 Patent.⁴

AFFIRMED-IN-PART, VACATED-IN-PART

COSTS

Each party shall bear its own costs.

⁴ For claims 3 and 4 of the '072 Patent, the Board shall also consider the obviousness combination in view of the '291 Application, to the extent applicable.