

UNITED STATES PATENT AND TRADEMARK OFFICE

BEFORE THE PATENT TRIAL AND APPEAL BOARD

MUNCHKIN, INC. AND TOYS “R” US, INC.
Petitioners

v.

LUV N’ CARE, LTD.
Patent Owner

Case IPR2013-00072
Patent D617,465

Before JENNIFER S. BISK, BENJAMIN D. M. WOOD, and
MICHAEL J. FITZPATRICK, *Administrative Patent Judges.*

FITZPATRICK, *Administrative Patent Judge.*

FINAL WRITTEN DECISION
35 U.S.C. § 318 and 37 C.F.R. § 42.73

I. BACKGROUND

Munchkin, Inc. and Toys “R” Us, Inc. (collectively, “Petitioner”) filed a petition (Paper 3, “Pet.”) requesting an *inter partes* review of the sole claim of U.S. Patent D617,465 (Ex. 1002, “the ’465 patent”). Patent Owner, Luv N’ Care, Ltd., did not file a preliminary response. In an April 25, 2013, Decision to Institute (Paper 8, “Dec. on Pet.”), we granted the petition and instituted trial of the patent claim on the following grounds: (1) as obvious over US 2007/0221604 A1, published September 27, 2007 (Ex. 1006, “Hakim ’604”); and (2) as obvious over US 6,994,225 B2, issued February 7, 2006 (Ex. 1013, “Hakim ’225”). Dec. on Pet. 23.

After institution, Patent Owner filed a response (Paper 14, “PO Resp.”), and Petitioner filed a reply (Paper 18, “Pet. Reply”). Additionally, Patent Owner filed a motion to amend the claim (Paper 13, “Mot.”), Petitioner filed an opposition (Paper 17, “Pet. Opp.”), and Patent Owner filed a reply (Paper 19, “PO Reply”). Oral hearing was held on January 22, 2014.¹

The Board has jurisdiction under 35 U.S.C. § 6(c). This final written Decision, issued pursuant to 35 U.S.C. § 318(a) and 37 C.F.R. § 42.73, addresses issues and arguments raised during the trial. Issues and arguments raised prior to institution of trial, but not made during trial, are not addressed necessarily in this Decision.

As discussed below, Petitioner has shown by a preponderance of the evidence that the sole claim of the ’465 patent is unpatentable, and Patent Owner has not met its burden of proof on the motion to amend.

¹ A transcript of the oral hearing is included in the record. Paper 26, “Tr.”

A. Related Proceedings

The following district court cases concerning the '465 patent have been identified by one or more of the parties: (1) *Luv N' Care, Ltd. v. Toys "R" Us, Inc.*, 1:12-cv-00228 (S.D.N.Y. filed Jan. 11, 2012); (2) *Luv N' Care, Ltd. v. Regent Baby Products Corp.*, 10-9492 (S.D.N.Y. filed Dec. 21, 2010); and (3) *Luv N' Care, Ltd. v. Royal King Infant Prod's Co. Ltd.*, 10-cv-00461 (E.D. Tex. filed Nov. 4, 2010). Paper 6, 2; Pet. 2.

Petitioner additionally identifies an *inter partes* reexamination of related U.S. Patent D634,439 bearing control no. 95/001,973. Pet. 2.

B. The '465 Patent (Ex. 1002)

The challenged '465 patent is titled "Drinking Cup," issued on June 8, 2010, names Nouri E. Hakim as inventor, and is assigned to Patent Owner. Ex. 1002, 1. The claim of the '465 patent recites "the ornamental design for a drinking cup, as shown and described." *Id.*; *see also Egyptian Goddess, Inc. v. Swisa, Inc.*, 543 F.3d 665, 679 (Fed. Cir. 2008) (en banc) (stating that "design patents 'typically are claimed as shown in drawings'") (quoting *Arminak and Assocs., Inc. v. Saint-Gobain Calmar, Inc.*, 501 F.3d 1314, 1319 (Fed. Cir. 2007)). The '465 patent includes five figures, reproduced below.

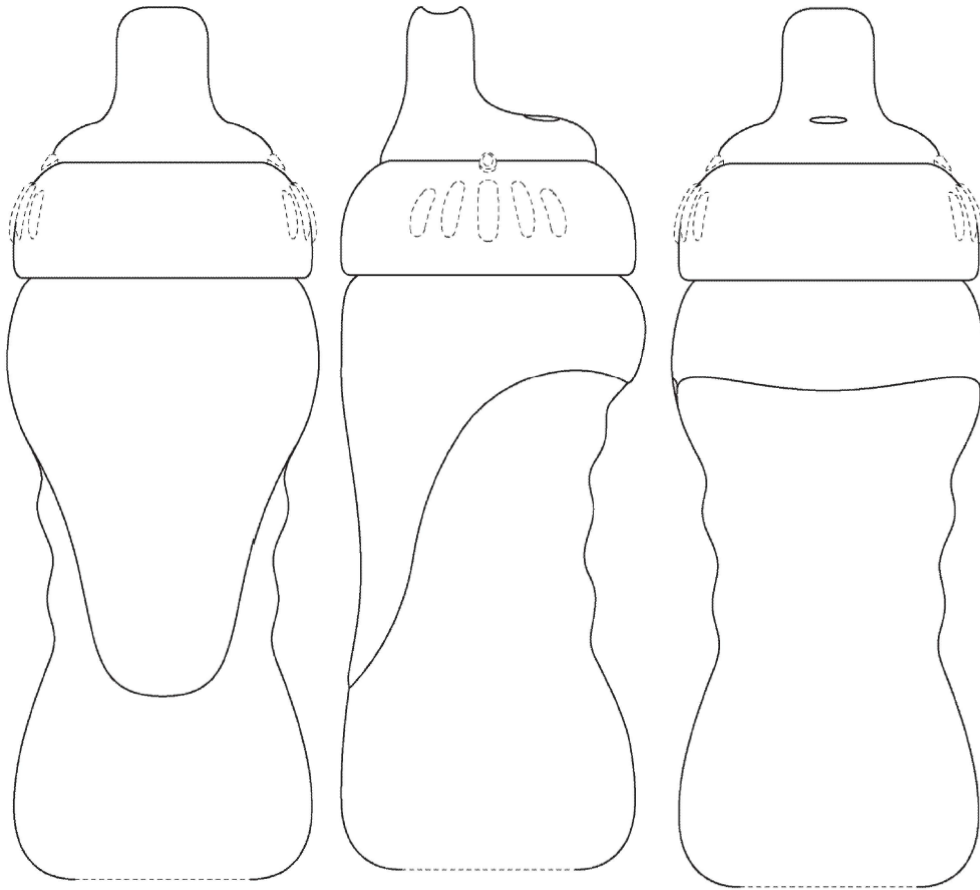

FIGURE 1

FIGURE 2

FIGURE 5

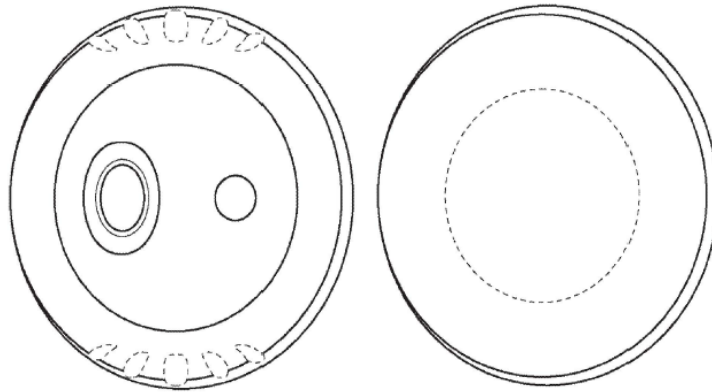

FIGURE 3

FIGURE 4

Figures 1-5 show front, right, top, bottom, and back views, respectively, of a drinking cup having a vessel, collar, and spout. Ex. 1002, 1. The “DESCRIPTION” of the ’465 patent identifies these five views, and

states that “[t]he broken lines in the figures illustrate portions of the drinking cup and form no part of the claimed design.”² *Id.*; *see also In re Owens*, 710 F.3d 1362, 1367 n.1 (Fed. Cir. 2013) (“[I]t is appropriate to disclaim certain design elements using broken lines, provided the application makes clear what has been claimed.”).

II. TRIAL OF THE ISSUED CLAIM

In instituting trial, we determined that there was a reasonable likelihood that the claim of the ’465 patent would have been obvious over each of Hakim ’225 and Hakim ’604. Dec. on Pet. 23. In response, Patent Owner does not argue that the claim is patentably distinct from those references. PO Resp. 6-7; Tr. 31:10-17. Rather, Patent Owner argues that the references are not prior art. PO Resp. 6-7; Tr. 31:10-17.

Hakim ’225 issued February 7, 2006, and Hakim ’604 was published September 27, 2007. Ex. 1013, 1; Ex. 1006, 1. The ’465 patent issued from U.S. Application serial no. 29/292,909 (“the ’909 application”), which was not filed until October 31, 2007. Ex. 1002, 1. However, the ’909 application was filed as a continuation of U.S. Application serial no. 10/536,106 (“the ’106 application”), which is the national stage of PCT Patent Application PCT/US2003/024400, filed August 5, 2003.³ Ex. 1002, 1; Ex. 1006, 1. Patent Owner argues that the claim of the ’465 patent is

² As shown in the figures, the broken lines are directed to a central portion of the bottom surface of the vessel, two series of five grooved ribs on the sides of the collar, and two notches adjacent to the top of the collar and bottom of the spout. Ex. 1002, Figs. 1-5.

³ Hakim ’604 (Ex. 1006) is a publication of the ’106 application (Ex. 3001).

entitled to an effective filing date of August 5, 2003, thereby disqualifying Hakim '225 and Hakim '604 as prior art. PO Resp. 5-7.

To be entitled to a parent's effective filing date under 35 U.S.C. § 120, a continuation must comply with the written description requirement.⁴ *Owens*, 710 F.3d at 1366.

The test for sufficiency of the written description, which is the same for either a design or a utility patent, has been expressed as “whether the disclosure of the application relied upon reasonably conveys to those skilled in the art that the inventor had possession of the claimed subject matter as of the filing date.”

Id. (quoting *Ariad Pharms., Inc. v. Eli Lilly & Co.*, 598 F.3d 1336, 1351 (Fed. Cir. 2010) (en banc)).

In the context of design patents, the drawings provide the written description of the invention. Thus, when an issue of priority arises under § 120 in the context of design patent prosecution, one looks to the drawings of the earlier application for disclosure of the subject matter claimed in the later application.

Owens, 710 F.3d at 1366 (citations omitted).

Petitioner argues that the '106 application lacks written description support for the claim of the '465 patent. Pet. 13-18. Petitioner's argument is based, in part, on differences between the spout of the claimed design and the spout described and shown in the '106 application. Pet. 16-18. Figure 3 of the '465 patent and Figure 12a of the '106 application are reproduced below, side-by-side, with an annotation and with Figure 3 being rotated 90°

⁴ The written description requirement, which is now found at 35 U.S.C. § 112(a), was codified previously at 35 U.S.C. § 112, ¶ 1 (1975).

counter-clockwise to align with Figure 12a.

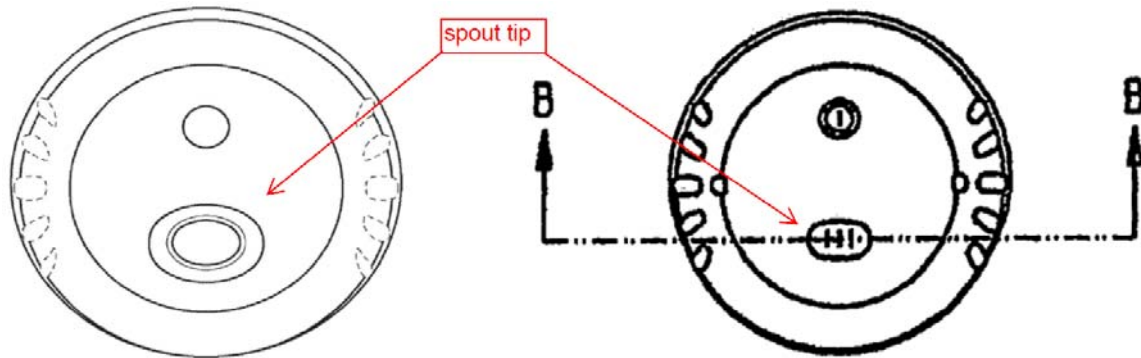

Fig. 3 of '465 patent
(rotated 90° counter-clockwise)

Fig. 12a of the '106 application

Figure 3 of the '465 patent and Figure 12a of the '106 application each illustrate a top view of a drinking cup having a spout, collar, and vessel, the vessels being barely visible. As can be seen, the claimed design of the '465 patent includes a spout tip that is different than that disclosed in the '106 application. Specifically, and as viewed from the top, (1) the outer boundary of the spout tip of the claimed design is larger than that of the '106 application; (2) the spout tip of the claimed design has a different, more rounded, oval shape than that of the racetrack shape of the spout tip in the '106 application; and (3) the spout tip of the claimed design has three concentric rings that the '106 application does not disclose.

Patent Owner argues that the '106 application provides an adequate written description, based on the following disclosure:

[I]n the preferred embodiment of the spout, the tube is in the shape of an oval when viewed from the top. Thus, the valve of the nipple preferably has an upper cylindrical section, and the valve of the spout preferably has an upper tubular section with an oval shape. Alternately, another shape may be provided if desired.

PO Resp. 6; Ex. 3001, 21.⁵ Although this excerpt from the '106 application discloses that an oval or other shape may be used for the spout, it does not identify the specific shape of the spout in the claimed design or otherwise reasonably convey to those skilled in the art that the inventor had possession of the claimed design. *See Ariad Pharms.*, 598 F.3d at 1351.

For the foregoing reasons, the claim of the '465 patent is not entitled to the benefit of the filing date of the '106 application. Accordingly, Hakim '225 and Hakim '604 are prior art to the claim of the '465 patent, which would have been obvious over either reference. *See* Dec. on Pet. 13-16; *see also* PO Resp. 6-7 (not arguing the claim is patentably distinct over Hakim '225 or Hakim '604); Tr. 31:10-17 (counsel for Patent Owner conceding that the claim is not patentable if it is denied the benefit of the filing date of the '106 application).

III. MOTION TO AMEND

During an *inter partes* review, a patent owner may file a motion to amend the patent. 35 U.S.C. § 316(d). The proposed amendment must be responsive to a ground of unpatentability at issue in the trial. 37 C.F.R. § 42.121(a)(2)(i). Additionally, it may not enlarge the scope of the claim(s) or introduce new subject matter. *Id.* at § 42.121(a)(2)(ii); *see also* 35 U.S.C. § 316(d)(3) (An amendment in an *inter partes* review “may not enlarge the scope of the claims of the patent or introduce new matter.”). A patent owner bears the burden to establish that it is entitled to the relief requested by its motion to amend. 37 C.F.R. § 42.20(c).

⁵ Patent Owner erroneously cites to Hakim '225, but the '106 application, as filed, also includes the relied-upon quote. *Compare* Ex. 1013, 12:45-51 with Ex. 3001, 21.

A. The Proposed Amendment

Patent Owner proposes to amend the claim of the '465 patent by amending the five drawings to which the claim refers. Mot. 2. Patent Owner includes the proposed replacement drawings in Ex. 2001. *See* Mot. 2 (referring to Exhibit 1 [sic, 2001]). Patent Owner also includes the replacement drawings in its motion, each juxtaposed with a corresponding drawing of the issued patent, as reproduced below, including Patent Owner's captions.

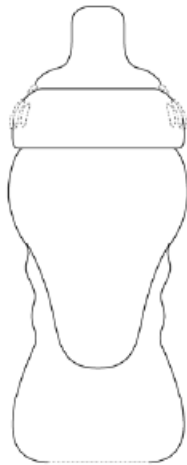

'465 Patent – Fig. 1

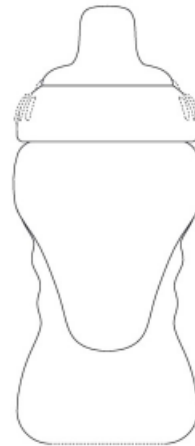
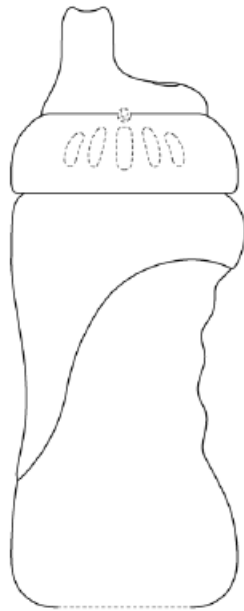

Fig. 1 Proposed Amendment



'465 Patent – Fig. 2

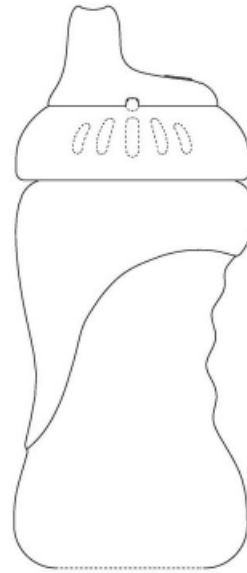
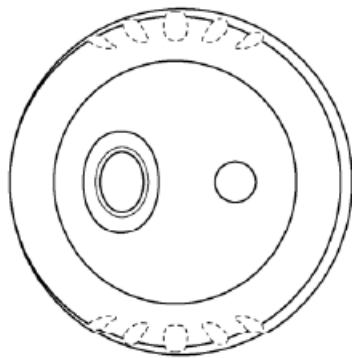

Fig. 2 Proposed Amendment



'465 Patent – Fig. 3

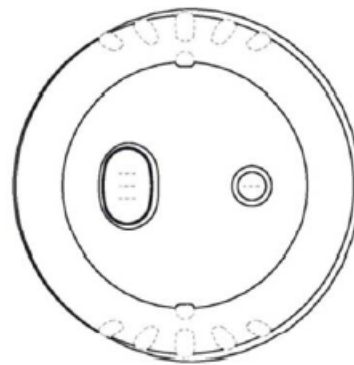
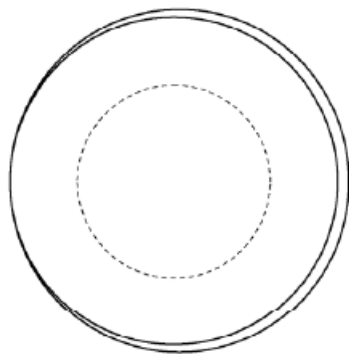

Fig. 3 Proposed Amendment



'465 Patent – Fig. 4

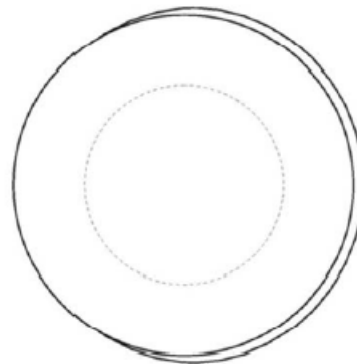
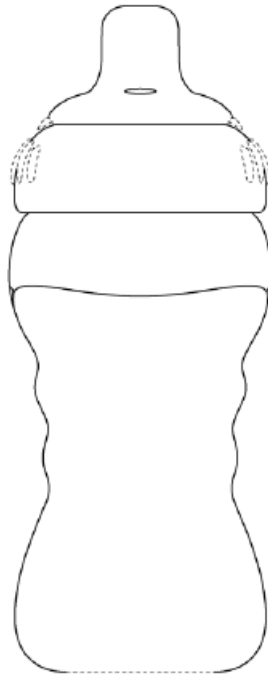

Fig. 4 Proposed Amendment



'465 Patent – Fig. 5



Fig. 5 Proposed Amendment

Mot. 2-4. Figures 1-5 of the issued patent and Figures 1-5 of the proposed amendment, reproduced above, side-by-side, show clearly the proposed change in claim scope, as required by 37 C.F.R. § 42.121(b).

B. Responsiveness to a Ground of Unpatentability

We instituted trial based on Hakim '225 and Hakim '604. Dec. on Pet. 23. In doing so, we made an initial determination that the claim of the '465 patent was not entitled, under 35 U.S.C. § 120, to the benefit of the filing date of the parent '106 application because the claim was not adequately described therein pursuant to 35 U.S.C. § 112(a). *Id.* at 6-8. The motion to amend seeks to amend the claim such that it would be supported by the disclosure of the '106 application, in order to disqualify Hakim '225 and Hakim '604 as prior art. Mot. 10. As such, the proposed amendment is

responsive to a ground of unpatentability at issue in the trial, as required by 37 C.F.R. § 42.121(a)(2)(i).

Petitioner contends that the motion to amend includes one change that is not responsive to a ground of unpatentability at issue in the trial. Pet. Opp. 2-3. In particular, Petitioner contends that Patent Owner has sought to amend the claim, not only via the replacement drawings, but also by changing the language of the claim from “the ornamental design for a drinking cup, as shown and described” to “the ornamental design for a drinking cup as shown.” *Id.* at 2 (referring to Ex. 2002). However, that contention is based on a misapprehension by Petitioner that Patent Owner’s Exhibit 2002 is part of the proposed amendment. It is not. *See* Mot. 2 (stating that Exhibit 1 [sic, 2001] contains the amendments), 6 (stating that Exhibit 2 [sic, 2002] is the ’909 application as originally filed).

C. Enlargement of Claim Scope

Petitioner contends that the proposed amended claim violates the prohibition on enlargement of claim scope in an *inter partes* review. *See* 35 U.S.C. § 316(d)(3); 37 C.F.R. § 42.121(a)(2)(ii). Petitioner’s contention that the amendment would broaden the claim scope is based, in part, on differences between the spout tip of the issued claim and that of the proposed amended claim. Pet. Opp. 5-7. Those differences can be seen best in a side-by-side comparison of Figure 3 of the ’465 patent with the corresponding replacement drawing of the proposed amended claim, as reproduced below from page 3 of the motion to amend, including Patent Owner’s captions.

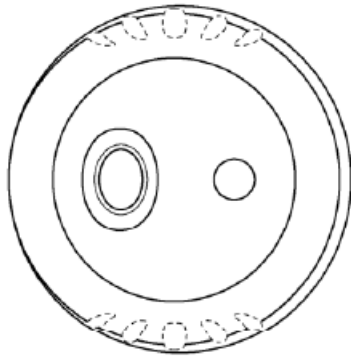

'465 Patent – Fig. 3

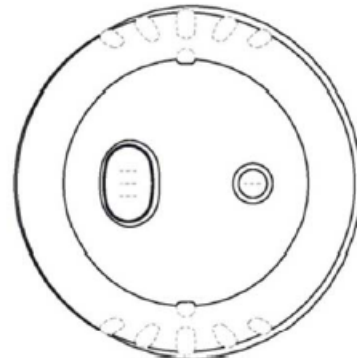

Fig. 3 Proposed Amendment

Figure 3 of the issued claim and Figure 3 of the proposed amended claim illustrate top views of the respective drinking cup designs. The spout tip (left of center in each drawing above) is egg-shaped in the issued claim, whereas it is racetrack-shaped in the proposed amended claim. Additionally, the spout tip of the issued claim includes three concentric rings, whereas that of the proposed amended claim includes only two concentric rings.

Petitioner's contention that the amendment would broaden the claim scope is based also on differences in the vent (right of center in each drawing above). Pet. Opp. 5-7. The slit that is present in the proposed amended claim is formed of a broken line. Thus, it is not part of the claim. However, another difference exists, which affects the scope of the claim. Specifically, the vent of the issued claim consists of a single circle, whereas the vent in the proposed amended claim includes two concentric rings, which are meant to signify that a raised rim has been added around the air vent. Mot. 6.

Infringement of a design patent is based on the design "as a whole," and does not require all "points of novelty" in the claimed design being present in the accused device. *Egyptian Goddess*, 543 F.3d at 677-78; *Hall v. Bed Bath & Beyond, Inc.*, 705 F.3d 1357, 1363 (Fed. Cir. 2013). Patent

Owner relies on this distinction, between infringement of design patents and that of utility patents, to argue that the proposed amended claim is not broader than the issued claim because, to “an ordinary observer,” the designs are “*substantially* the same.” PO Reply 4 (emphasis added). However, Patent Owner does not direct us to, and we are not aware of, any authority that has applied the “ordinary observer” test—first enunciated as a test for infringement in *Gorham Manufacturing Co. v. White*, 81 U.S. 511 (1871) and adopted as the sole test for design patent infringement in *Egyptian Goddess*, 543 F.3d at 678—to compare the scope of two claims.

The scope of the issued claim and the proposed amended claim are defined by the respective drawings. *See id.* at 679 (design patents typically are claimed as shown in the drawings). Those drawings differ with respect to the spout tip and the vent. Specifically, the proposed amended claim is broader than the issued claim because it is broader with respect to racetrack-shaped spout tips and raised rim vents, even though it may be narrower with respect to egg-shaped spout tips and vents without raised rims. *See In re Rogoff*, 261 F.2d 601, 603 (CCPA 1958) (“[A] claim is broadened if it is broader in any respect than the original claim, even though it may be narrowed in other respects.”). In other words, a drinking cup, having the racetrack-shaped spout tip and raised rim vent of the proposed amended claim, could infringe the proposed amended claim based on its overall design, yet not infringe the issued claim. *See Thermalloy, Inc. v. Aavid Eng’g, Inc.*, 121 F.3d 691, 692 (Fed. Cir. 1997) (“A new claim enlarges if it includes within its scope any subject matter that would not have infringed the original patent.”). Therefore, the proposed amended claim would

enlarge the claimed subject matter in violation of 35 U.S.C. § 316(d)(3) and 37 C.F.R. § 42.121(a)(2)(ii).

IV. CONCLUSION

Petitioner has demonstrated by a preponderance of the evidence that the sole claim of the '465 patent is unpatentable under 35 U.S.C. § 103 as obvious over Hakim '225 and over Hakim '604.

Patent Owner's motion to amend is denied because it seeks to enlarge the scope of the claim.

V. ORDER

In consideration of the foregoing, it is hereby:

ORDERED that the claim of the '465 patent is held *unpatentable*;

FURTHER ORDERED that Patent Owner's motion to amend the claim of the '465 patent is *denied*; and

FURTHER ORDERED that, because this is a final decision, parties to the proceeding seeking judicial review of the decision must comply with the notice and service requirements of 37 C.F.R. § 90.2.

Case IPR2013-00072

Patent D617,465

PETITIONER:

A. Poplin

Hissan Anis

LATHROP & GAGE LLP

JPoplin@LathropGage.com

hanis@lathropgage.com

Dane Baltich

ALSTON & BIRD LLP

dane.baltich@alston.com

PATENT OWNER:

Morris Cohen

Lee A. Goldberg

GOLDBERG COHEN LLP

mcohen@goldbergcohen.com

lgoldberg@goldbergcohen.com